

FS15U120PB & FS15U240PB SERIES 15 AMP PUMP UP FLOAT SWITCHES

The FS15UxxxPB Series Pump Switch is used to turn a pump on and off in environments with temperatures up to 140° F. This product can be used for a variety of applications, including but not limited to: septic tanks, sump pits, holding tanks, pump chambers, water tanks, and any other liquid tanks. Available in 120VAC piggyback plug, and 240VAC piggyback plug.

The pump switches are mechanically operated using a microswitch and are activated by the ball inside the float housing. Available models include: FS15 Series with wide angle switching differential. For use as fill tank (normally closed) configuration with multiple types of float attachments for mounting and various cable lengths.

NOTE: Check to make sure the correct pump switch is being used for the application:

Normally Closed (Pump Up) - Contacts are closed while hanging down and will open on a rising liquid level. Typically used for fill tank applications.

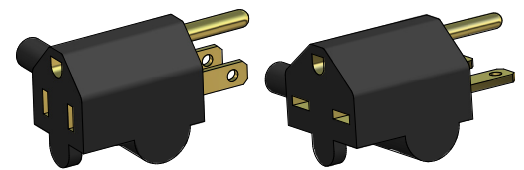

120VAC
piggyback plug

240VAC
piggyback plug

(1) Polypropylene Housing - Designed for temperatures up to 140° F, resistant to harsh chemicals, and withstands high impact. The ridge-less housing design creates optimum operation of the pump float switch and prevents materials from adhering to the housing.

(2) Cable Type - SJ00W (UL/CSA), 14 gauge, 2-conductor, flexible, and water/oil resistant. Available in 120VAC piggyback plug, and 240VAC piggyback plug.

(3) Internal Wiring - Solder dipped wiring with an epoxy filled chamber for moisture seal technology and protection from water intrusion (solder dipped wiring on bare lead models only).

(4) Ball - Located inside the float housing and used to actuate the microswitch.

(5) Microswitch - Activated by the ball inside the float housing causing the contacts to open or close.

(6) Actuator Arm - As the float tilts above/below horizontal, the ball inside the housing will activate or deactivate the actuator arm causing the microswitch to turn on/off.

(7) Switching Differential - wide angle (90°) switching differential.

(8) Innovative Mechanical Design - Using mechanically activated snap action contacts eliminates the hazardous mercury for an environmentally safe product.

(9) Omni-Directional (not shown) - Not sensitive to either rotation or turbulence. The float switch will operate at the designed angle regardless of the direction of the tilt.

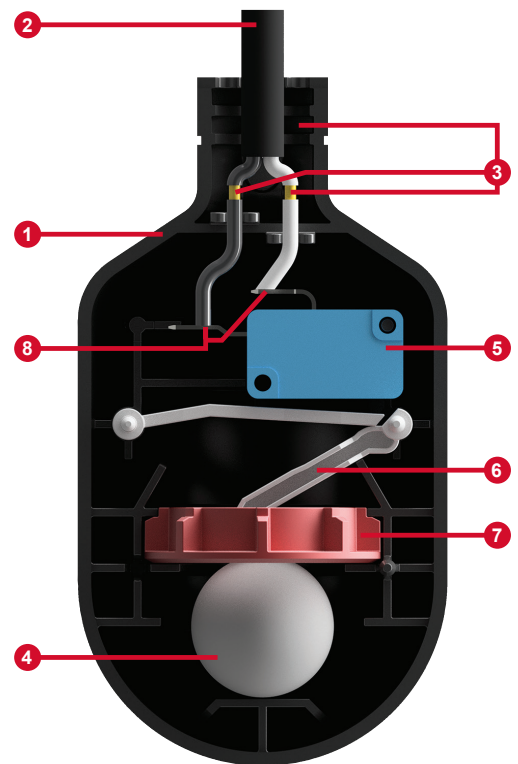

BOSHART
INDUSTRIES

25 Whaley Avenue, PO Box 310, Milverton, ON CANADA N0K 1M0
Tel: 800-561-3164

boshart.com ♦ blog.boshart.com

FS15U120PB & FS15U240PB SERIES 15 AMP PUMP UP FLOAT SWITCHES



SPECIFICATION:

- Primary Voltage: 120VAC or 240VAC, 60 Hz (voltage depends on model/part number)
- Amperage: 15 Amps, 120VAC 0.5HP or 240VAC 2.0HP
- Float Housing Material: Polypropylene
- Float Housing Size: 2.6 inches (diameter) x 4.8 inches (length)
- Cable Type: SJOOW (UL/CSA), 14 gauge, 2-conductor, flexible, and water/oil resistant
- Connection Types: Piggyback Plug (120VAC or 240VAC)
- Operating Temperature: 0 - 140° F
- Switching Differential: 90° total (wide angle)
- Switch Configuration: Single Pole, Single Throw (Pump Up only)
- Mounting Method(float attachment): Pipe Clamp, Stainless Steel
- Certifications: CSA (US and Canada)

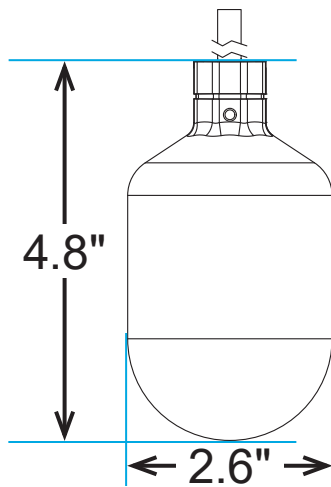

Tether Length Guide									
Tether Length (inches)	3.5"	4"	6"	8"	10"	12"	16"	20"	24"
Pumping Range (inches)									
Wide Angle	7.5"	8.25"	9.75"	13.3"	15.8"	20"	25.5"	32"	40"

CAUTION: USE AS GUIDE ONLY, ACTUAL RANGES MAY VARY
(Reference Only - Testing Must Be Performed for Actual Ranges)

Pump Switches - minimum recommended tether of 3.5"

Part No.	Model No.	Cable Length feet
Wide angle; 15 Amps, 120VAC 0.5HP		
FS15U120PB-10	A15WUPS1WP10	10'
FS15U120PB-20	A15WUPS1WP20	20'
FS15U120PB-30	A15WUPS1WP30	30'
Wide angle; 15 Amps, 240VAC 2.0HP		
FS15U240PB-10	A15WUPS2WP10	10'
FS15U240PB-20	A15WUPS2WP20	20'
FS15U240PB-30	A15WUPS2WP30	30'

EMPTY TANK (normally closed example)

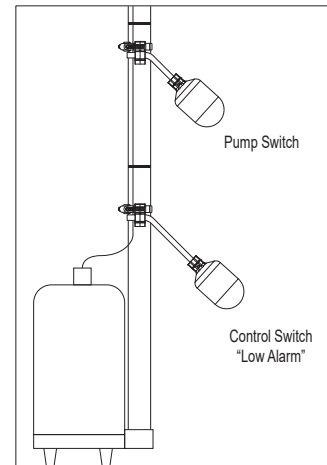

Multiple float switches with pipe clamps are used for a variety of applications to empty/fill a tank or use as high/low level alarms.

Normally Open (Pump Down):

Control Switch / Top Float = High Alarm
Pump Switch / Bottom Float = Start/Stop Pump

Normally Closed (Pump Up):

Pump Switch / Top Float = Start/Stop Pump
Control Switch / Bottom Float = Low Alarm

For more information on installation, adjustment, repair & operation, visit Boshart Knowledge Base at

SUPPORT.BOSHART.COM



BOSHART INDUSTRIES

25 Whaley Avenue, PO Box 310, Milverton, ON CANADA N0K 1M0
Tel: 800-561-3164

boshart.com ♦ blog.boshart.com