

17CVSS SERIES - 304SS THREADED CHECK VALVES

Check Valves, sometimes referred to as non-return or one way valves, allow the flow of fluid in one direction only. The flow direction is typically indicated by an arrow on the valve body. They are commonly used in the installation of a submersible pump. Their purpose is to prevent the flow of fluid in the opposite direction and to maintain system pressure when the pump stops. Check valves work automatically and are opened by the pumps pressure against a low tension spring, normally ½ PSI or less cracking pressure (cracking pressure is the pressure it takes to open the valve). When the pump stops the valve starts closing automatically with assistance of the spring as the flow slows, and is completely sealed before it comes to a full stop. This eliminates flow reversal which would cause the poppet to slam against the seat causing hydraulic shock or water hammer. Without a check valve gravity would cause the water or fluid to flow in the reverse direction, draining system pressure and potentially causing damage to the pump and or piping system.

APPLICATIONS:

- Check valves are mainly used in potable water, irrigation, and wastewater (without solids) applications



SPECIFICATIONS:

- Threads conform to ANSI/ASME B1.20.1
- Cast 304SS body and poppet
- FPM Viton® rubber O-ring seal
- Cracking pressure equal to or less than 0.5 PSI for 1/2" through 4" valves
- Best practice is to install check valves vertically with the arrow pointed up in the direction of liquid flow. (1/2" through 1-1/4" sizes can be installed horizontally)

CERTIFICATION:

- NSF/ANSI/CAN Standard 372 Certified (Drinking Water System Components - Lead Content - Stainless Steel alloys do not contain any lead, 0.00% Pb)*
 - * 17CVSSMF-125-100 - not covered on these certificates

RATINGS:

- Maximum Pressure: 200 PSI WOG Non-Shock
- Maximum Temperature: 180 °F (82 °C)
- Headloss - see page 3 for detailed information
- Velocity - see page 3 for detailed information
- CV Rating - see page 3 for detailed information

WARNING: Poppet style check valves are not recommended for VFD (Variable Frequency Drive) systems, as variable flow conditions may cause valve chatter, resulting in premature wear and reduced service life.

BOSHART
INDUSTRIES

25 Whaley Avenue, PO Box 310
Milverton, ON CANADA N0K 1M0
Tel: 800-561-3164

VISIT US ONLINE AT BOSHART.COM

For more information on installation,
adjustment, repair & operation, visit
Boshart Knowledge Base at
SUPPORT.BOSHART.COM





17CVSS-150

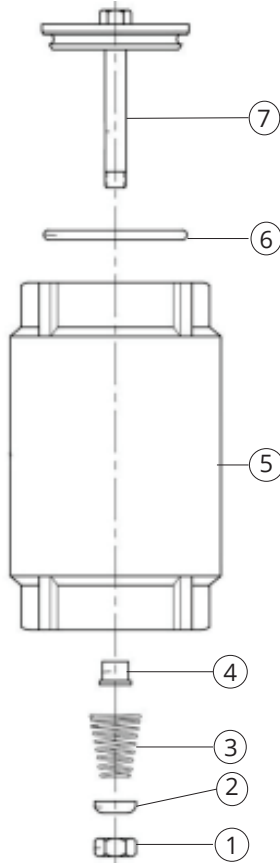
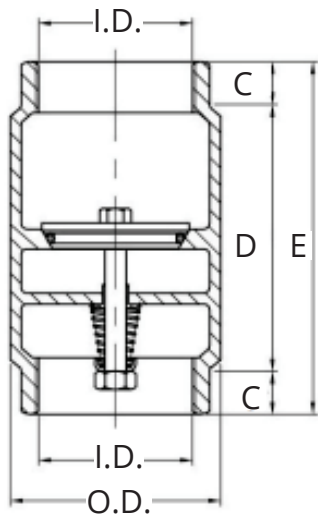

MATERIAL LIST		
No.	Part Name	Material
1	Hex Nut	304 Stainless Steel
2	Cup Washer	304 Stainless Steel
3	Spring	304 Stainless Steel
4	Bushing	Polyethylene
5	Body	304 Stainless Steel
6	O-Ring	FPM (Viton®) (Fluoro Rubber)
7	Poppet	304 Stainless Steel

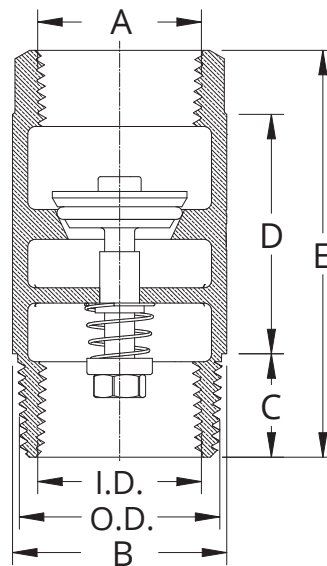

***17CVSSMF-125
FPT x MPT**

DIMENSIONS												
Part No.	I.D. (Inside Diameter)	O.D. (Outside Diameter)	B		C		D		E		Weight	
			in	mm	in	mm	in	mm	in	mm	lbs	grams
17CVSS-050	1/2" FPT	~	1.26	32.00	0.39	10.01	1.64	41.81	2.43	61.79	0.37	170
17CVSS-075	3/4" FPT	~	1.49	38.00	0.40	10.21	1.90	48.49	2.71	69.01	2.51	230
17CVSS-100	1" FPT	~	1.77	45.01	0.47	11.99	2.28	57.99	3.22	81.99	0.73	330
17CVSS-125	1-1/4" FPT	~	2.12	54.00	0.53	13.49	2.55	65.00	3.62	91.99	1.21	550
17CVSS-150	1-1/2" FPT	~	2.36	59.99	0.61	15.49	2.82	71.70	4.04	102.69	1.43	650
17CVSS-200	2" FPT	~	3.03	76.99	0.65	16.51	3.74	95.00	5.03	127.99	2.73	1240
17CVSS-300	3" FPT	~	4.21	107.00	1.18	30.00	4.92	124.99	7.28	184.99	8.93	4050
17CVSS-400	4" FPT	~	5.51	140.00	1.96	50.01	6.45	164.01	10.39	264.01	17.79	8070
17CVSSMF-125-100*	1" FPT	1-1/4" MPT	1.77	45.01	0.47	11.99	2.28	57.99	3.22	81.99	0.82	370

*not covered by NSF/ANSI/CAN 372 certificate



25 Whaley Avenue, PO Box 310
 Milverton, ON CANADA N0K 1M0
 Tel: 800-561-3164

VISIT US ONLINE AT BOSHART.COM

For more information on installation,
 adjustment, repair & operation, visit
 Boshart Knowledge Base at
SUPPORT.BOSHART.COM



FLOW COEFFICIENT: Flow Coefficient (Cv) is the number of U.S. gallons that can pass through a valve when it is in the fully opened position at a pressure drop of 1 PSI. Testing is typically done by running water (specific gravity of 1.0 centistoke viscosity) at 60°F (°C) unless stated otherwise.

Valve Size	1/2"	3/4"	1"	1-1/4"	1-1/2"	2"	3"	4"
Flow Coefficient (CV)	5.0	6.2	9.6	20.1	30.1	41.2	65.0	95.0

The Cv is used to properly size valves, so they have minimal effect on the hydraulic efficiency of your system. Flow Coefficient or Cv is one of the most important things to know for selecting the right size of valve. For example, a 1-1/4" valve with a Cv of 20.1 has an effective port area in the fully open position such that it is capable of passing 20.1 GPM of water with a pressure drop of 1 PSI.

VELOCITY: It is also important to take Flow Velocity into consideration when selecting a valve, larger pipe is more expensive, however keeping the water velocity low is important to limit pressure losses due to friction, water hammer, and pipe movement due to water momentum changes inside the pipe. It is recommended to size piping to maintain a water velocity of 5 ft/second (1.524 LPM). Five feet per second is a threshold that is widely accepted by engineers and designers because beyond this velocity, the friction losses, danger of water hammer, and pipe movement due to water momentum changes are deemed to be too high.

Maximum Flow Rates to Maintain Fluid Velocity of 5 fps (1.523m/s)								
Nominal Valve / Pipe Size	1/2"	3/4"	1"	1-1/4"	1-1/2"	2"	3"	4"
GPM at 5 fps (feet / second)	3.06	6.89	12.25	19.15	27.57	49.02	110.29	196.08
LPM at 1.524 m/s (meters / second)	11.57	26.04	46.30	72.34	104.17	185.19	416.67	704.75

HEAD LOSS: Head loss is a measure of the reduction in the total head (sum of elevation head, velocity head and pressure head) of the fluid as it moves through a fluid system. The chart below provides the head loss data for these series of valves. You will notice that when the flow velocity is maintained the head loss across the valves is typically 1.5 PSI or less (except for the 4" valves at approx. 2.3 PSI)

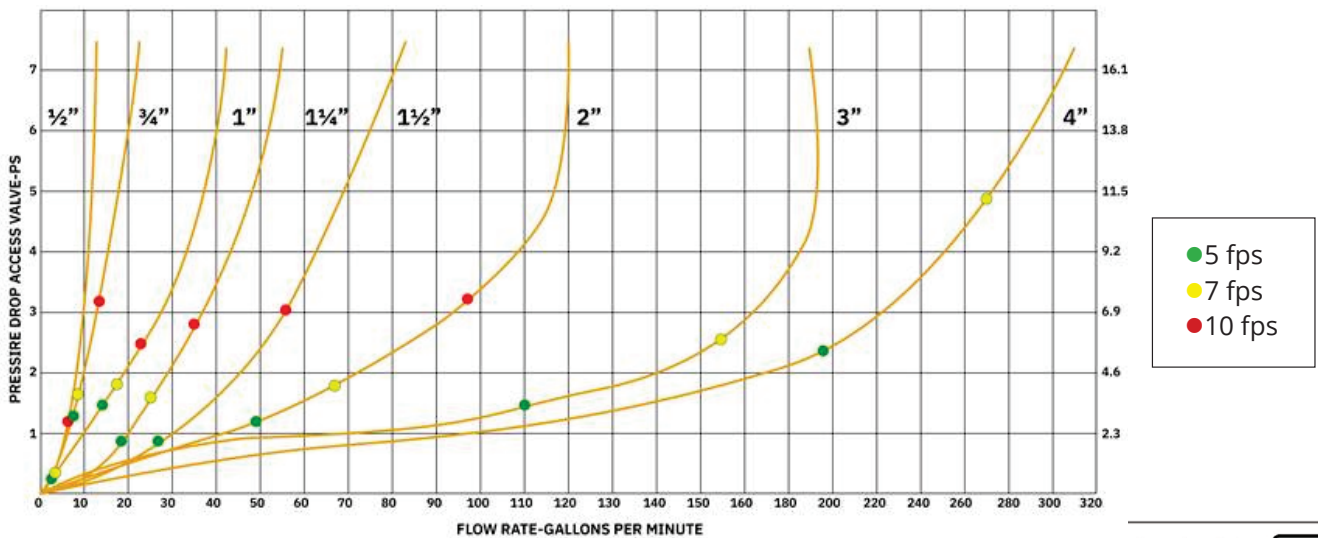

Milverton, ON CANADA NUK 1MU
 Tel: 800-561-3164
 VISIT US ONLINE AT BOSHART.COM

For more information on installation, adjustment, repair & operation, visit Boshart Knowledge Base at SUPPORT.BOSHART.COM



REPLACEMENT PARTS:

POPPET ASSEMBLIES:

- Replacement poppet assemblies are material specific to match the material of the check valve.

REPLACEMENT POPPET ASSEMBLIES	
Part No	Fits S.S. Check Valve Size
17PT-CVSS300-PA	3"
17PT-CVSS400-PA	4"

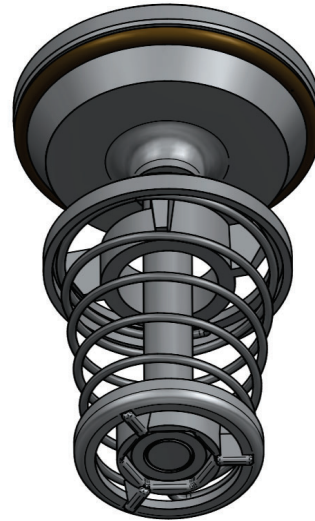

It is the user's sole responsibility to determine the product's suitability for its intended use. For full details, visit Boshart Industries [Reference Documents](#) for our User Safety Responsibility Statement and other important documents.

