

# 0851 SERIES BRASS SEDIMENT FAUCETS

## SPECIFICATION:

- Inlet Threads conform to ANSI/ASME B1.20.1
- 1/2" has combination MPT & 1/2" solder inlet connection
- Solder ends comply with ANSI B16.18
- Hose thread outlet 3/4" GHT
- Max Pressure Rating: 125 PSI
- Max Temperature Rating: 180°F (82°C)
- Black cast hand wheel



## CERTIFICATION:

- CSA B125.1 Certified



MATERIAL LIST		
Part No.	Part Name	Material
1	HandWheel Nut	Brass Plated Steel
2	Name Plate	Aluminum
3	Hand Wheel	Black Powder Coated Cast Iron
4	Packing Nut	C36000 Brass
5	Gland Packing	NBR-Rubber
6	Stem	C85700 Brass
7	Seat Packing	NBR-Rubber
8	Seat Packing Screw	SS304 Stainless Steel
9	Body	C85700 Brass
10	Bonnet	C85700 Brass

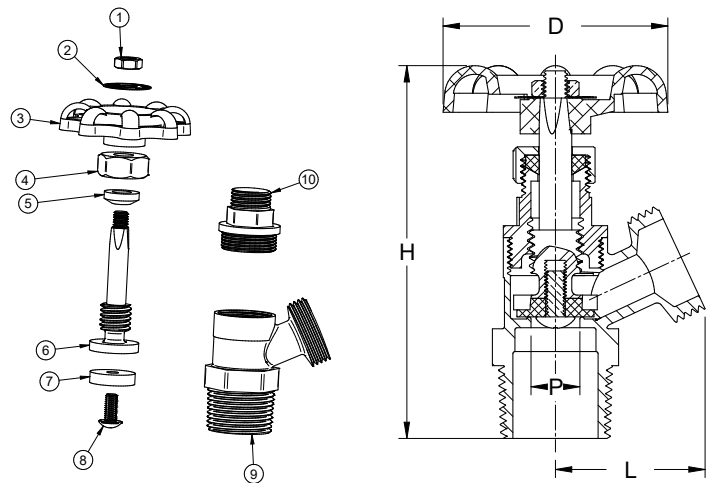
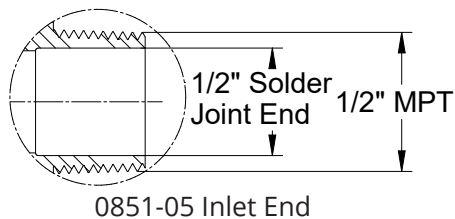

DIMENSIONS											
Part No.	Inlet Connection	P (Port)		D		H		L		Weight	
		inches	mm	inches	mm	inches	mm	inches	mm	grams	Lbs
0851-05	1/2" MPT x C	0.45	11.40	2.07	52.50	3.30	83.82	1.34	34.00	152	0.335
0851-07	3/4" MPT	0.45	11.40	2.07	52.50	3.30	83.82	1.34	34.00	172	0.379



25 Whaley Avenue, PO Box 310, Milverton, ON CANADA N0K 1M0  
Tel: 800-561-3164

[boshart.com](http://boshart.com) ♦ [blog.boshart.com](http://blog.boshart.com)