

Table of Contents



0861 Series
MPT or Copper x GHT
Pages 2 to 5



08QTWH(NL) Series
MPT, Copper, FPT, PEX x GHT
Pages 6 to 11



0865(P)(NL) Series
MPT, Copper, PEX x GHT
Page 12 to 23



Installation for Trouble-Free Operation
Installation Guide
Page 24 & 25



0861-NL SERIES NO LEAD NON-FREEZE WALL HYDRANT

Boshart's Non-Freeze Wall Hydrant can be installed through a wall and allow water to drain back out of the valve so freezing will not occur in the winter season. This prevents the need for winterizing and allows outdoor access to water year round.

CAUTION: Boshart will not be liable for any damage caused by failure to remove the hose or any attached device. Failure to do so may cause the hydrant to freeze. Freezing can lead to the tube bursting, resulting in property damage and may void the warranty. Boshart will not be liable for any damage caused by failure to remove the hose or attached device. Wall hydrants are not intended for potable water supply.

FEATURES:

- Chrome plated no lead brass body and tube
- Stem comes with a weep hole to allow back pressure relief when water is trying to siphon back into the homes water supply
- Rubber Sealing Disc
- Rubber Stem Packing

SPECIFICATION:

- Inlet Connection:
 - Threads conform to ANSI/ASME B1.20.1 Pipe Threads, General Purpose (Inch)
 - Sweat connection conforms to ANSI B16.18 Cast Copper Alloy Solder Joint Pressure Fittings
- Outlet Connection:
 - ASME B1.20.7 Standard for Garden Hose Coupling Screw Threads (inch)

RATINGS:

- Max Pressure Rating: 125 PSI
- Max Temperature Rating: 120°F (49°C)

CERTIFICATION:

- NSF/ANSI Standard 61 Certified (Drinking Water System Components - Health Effects)
- NSF/ANSI Standard 372 Certified (Drinking Water System Components - Lead Content)
- CSA Standard B125.1 Plumbing Fittings Certified



White flange wedge can be used to ensure downward tilt.
"REMOVE HOSE IN FREEZING WEATHER"

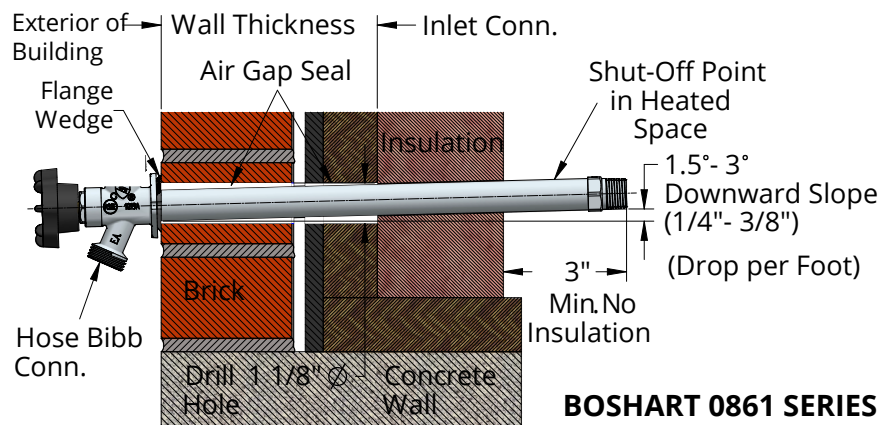

BOSHART 0861 SERIES

Short bursts of water can occur from vacuum breaker, but will stop. If it continues to leak, vacuum breaker should be replaced



25 Whaley Avenue, PO Box 310, Milverton, ON CANADA N0K 1M0
Tel: 800-561-3164
VISIT US ONLINE AT BOSHART.COM



REPLACEMENT PARTS		
Part No.	Description	Components
0861PT-HDL	Replacement Handle	3
0861PT-VSK	Replacement Valve Seal Kit	13, 14
0861PT-SPK	Replacement Stem Packing Kit	4 to 7
0861PT-SA08	8" Replacement Stem Assembly	6, 10, 11, 13, 14
0861PT-SA10	10" Replacement Stem Assembly	
0861PT-SA12	12" Replacement Stem Assembly	
0861PT-SA14	14" Replacement Stem Assembly	

MATERIAL LIST		
Part No.	Part Name	Material
1	Handle Bolt	C27000 No Lead Brass
2	Name Plate	1100 Aluminum
3	Handwheel	Zinc
4	Stem Packing Nut	C36000 No Lead Brass
5	Stem Packing Washer	304 Stainless Steel
6	Stem Packing	NBR (Nitrile Butadiene Rubber)
7	Stem Packing Flat Washer	304 Stainless Steel
8	Body	C46500 Chrome Plated No Lead Brass
9	Tube	C26000 Chrome Plated No Lead Brass
10	Stem Pipe	C27000 No Lead Brass
11	Stem	C46500 No Lead Brass
12	Seat	C46500 No Lead Brass
13	Seat Packing	Rubber NBR (Nitrile Butadiene Rubber)
14	Seat Screw	C27000 No Lead Brass
15	Flange Wedge/Insert Spacer	LDPE (Low-Density Polyethylene)

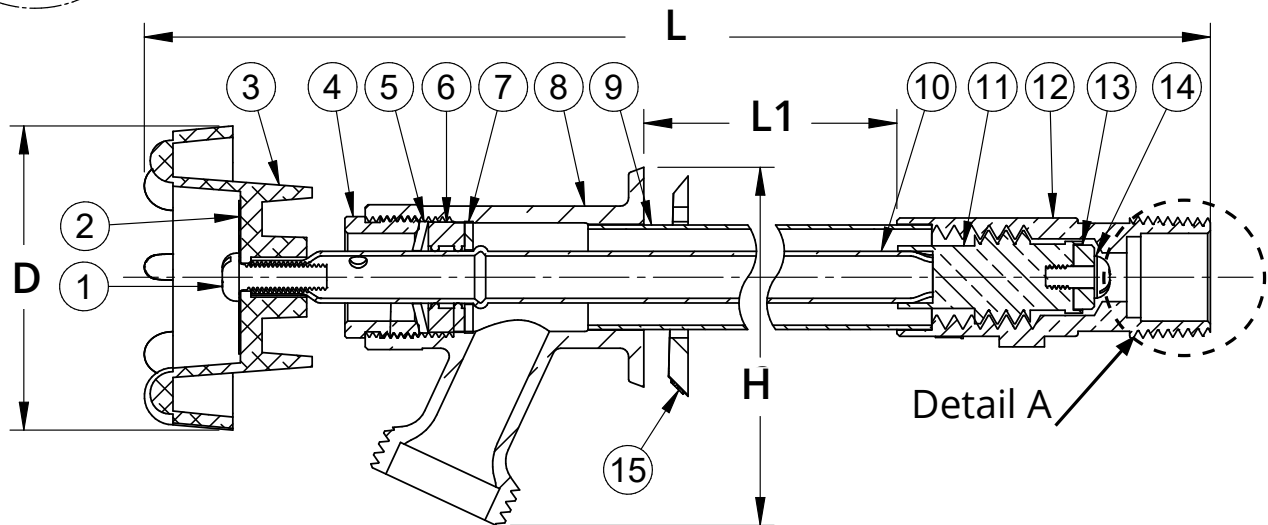
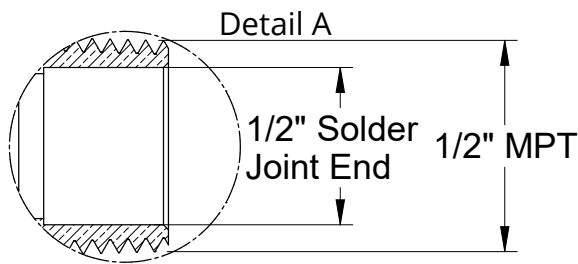

DIMENSIONS												
Part No.	Description	Size	D		L		L1		H		Weight	
			in	mm	in	mm	in	mm	in	mm	lbs	grams
0861-080NL	1/2" MPT or Copper x 3/4" GHT	8"	2.15	54.50	12.65	321.00	7.28	185	2.84	72.00	0.91	411
0861-100NL	1/2" MPT or Copper x 3/4" GHT	10"	2.15	54.50	14.66	372.00	9.25	235	2.84	72.00	0.96	437
0861-120NL	1/2" MPT or Copper x 3/4" GHT	12"	2.15	54.50	16.67	423.00	11.22	285	2.84	72.00	0.98	446
0861-140NL	1/2" MPT or Copper x 3/4" GHT	14"	2.15	54.50	18.68	474.00	13.19	335	2.84	72.00	1.08	491



25 Whaley Avenue, PO Box 310, Milverton, ON CANADA N0K 1M0
 Tel: 800-561-3164
 VISIT US ONLINE AT BOSHART.COM



0861 SERIES REPLACEMENT PARTS

0861HPT-HDL - Replacement Handle

- Handwheel only

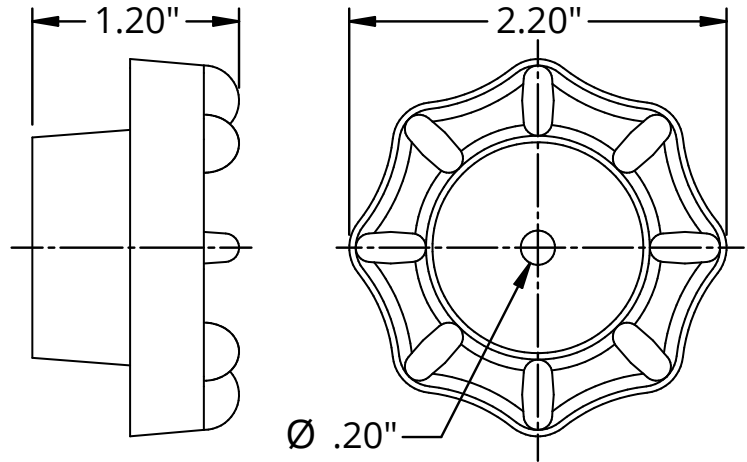

0861PT-VSK - Replacement Valve Seal Kit

- Includes seat packing and seat screw

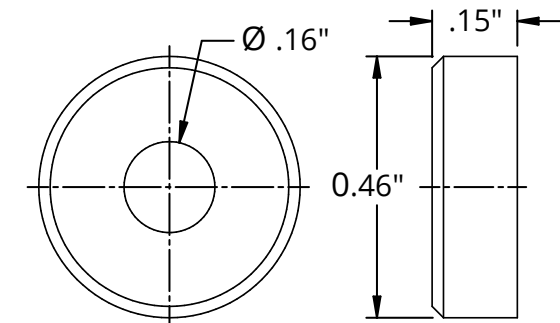

Seat Packing

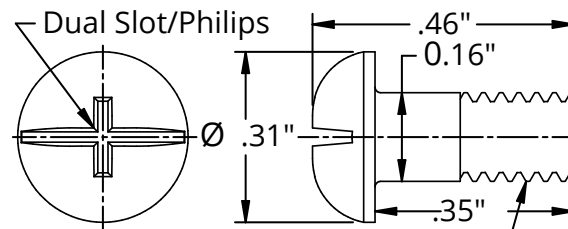

No. 8-32 UNC Thread

Seat Screw



25 Whaley Avenue, PO Box 310, Milverton, ON CANADA N0K 1M0
Tel: 800-561-3164
VISIT US ONLINE AT BOSHART.COM

For more information on installation, adjustment, repair & operation, visit Boshart Knowledge Base at SUPPORT.BOSHART.COM



0861HPT-SPK - Replacement Stem Packing Kit

- Includes bonnet, washer, stem packing and stop washer

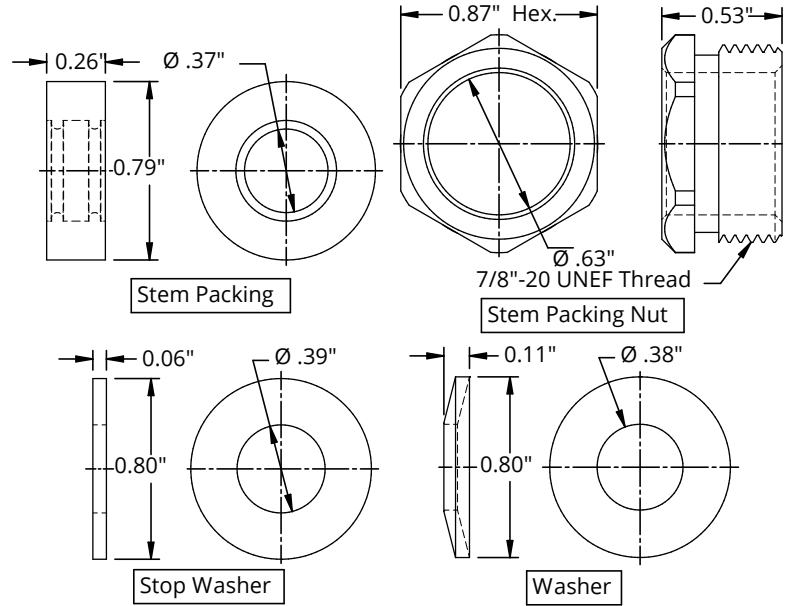

0861PT-SA(xx) - Stem Assembly

- Available in 8", 10", 12" and 14" lengths



Determining Stem Length

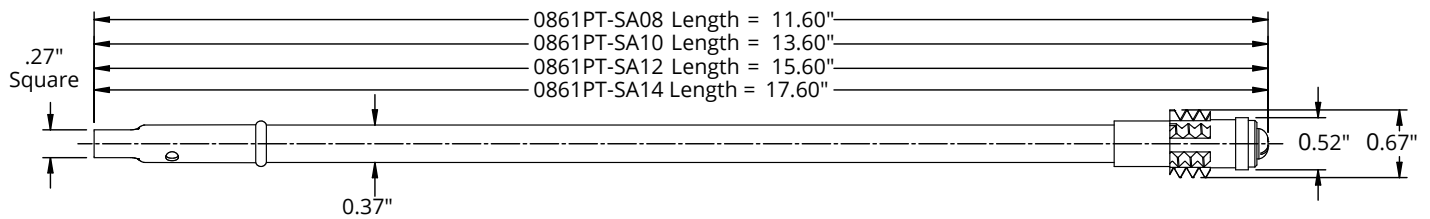
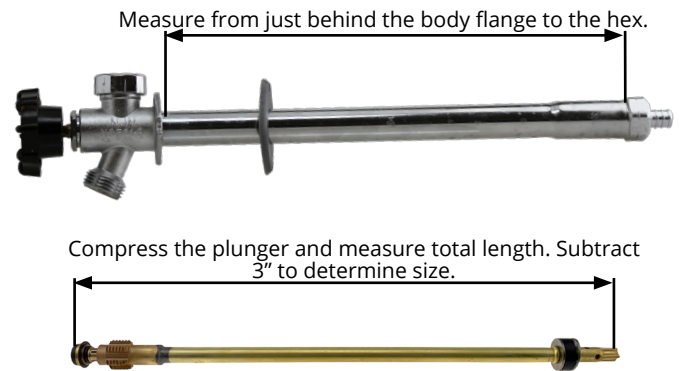

BOSHART
INDUSTRIES

25 Whaley Avenue, PO Box 310, Milverton, ON CANADA N0K 1M0
Tel: 800-561-3164
VISIT US ONLINE AT BOSHART.COM

For more information on installation, adjustment, repair & operation, visit Boshart Knowledge Base at SUPPORT.BOSHART.COM



08QTWH(P)NL SERIES NO LEAD NON-FREEZE WALL HYDRANT WITH SELF DRAINING VACUUM BREAKER

1/4 TURN HANDWHEEL

Non-Freeze Wall Hydrants can be installed through a wall and allow water to drain back out of the valve so freezing will not occur in the winter season. This prevents the need for winterizing and allows outdoor access to water year round.

CAUTION: Boshart will not be liable for any damage caused by failure to remove the hose or any attached device. Failure to do so may cause the hydrant to freeze. Freezing can lead to the tube bursting, resulting in property damage and may void the warranty. Boshart will not be liable for any damage caused by failure to remove the hose or attached device. Wall hydrants are not intended for potable water supply.

FEATURES:

- Integral anti-siphon vacuum breaker to allow air to enter the valve, ensuring the valve drains completely
- Stem comes with a weep hole to allow back pressure relief when water is trying to siphon back into the homes water supply
- Chrome plated no lead brass body, tube and adapter
- Black cast 1/4 turn handwheel
- Inlet cartridge has built in spring loaded check valve for backflow prevention
- Sloped flange to support proper drainage, this is necessary for frost-proof performance
- NBR Packing
- Viton O-Ring seat
- POM (Acetal) Sealing discs are known for their outstanding toughness, they provide longevity (POM discs are not negatively affected by hard water and are not susceptible to cracking like ceramic discs)

SPECIFICATION:

- Inlet Connection:
 - Threads conform to ANSI/ASME B1.20.1 Pipe Threads, General Purpose (Inch)
 - Sweat connections conform to ANSI B16.18 Cast Copper Alloy Solder Joint Pressure Fittings
 - Crimp PEX connections conform to ASTM F1807 Specification for Metal Insert Fittings Utilizing a Copper Crimp Ring for SDR9 Cross-linked Polyethylene (PEX) Tubing
- Outlet Connection:
 - ASME B1.20.7 Standard for Garden Hose Coupling Screw Threads (inch)

RATINGS:

- Max Pressure Rating: 125 PSI
- Max Temperature Rating: 140°F (60°C)

CERTIFICATION:

- NSF/ANSI Standard 372 Certified (Drinking Water System Components - Lead Content)
- CSA Standard B125.1 Plumbing Fittings Certified
- ASSE Standard 1019 Performance Requirements for Vacuum Breaker Wall Hydrants, Freeze Resistant, Automatic Draining Type Certified

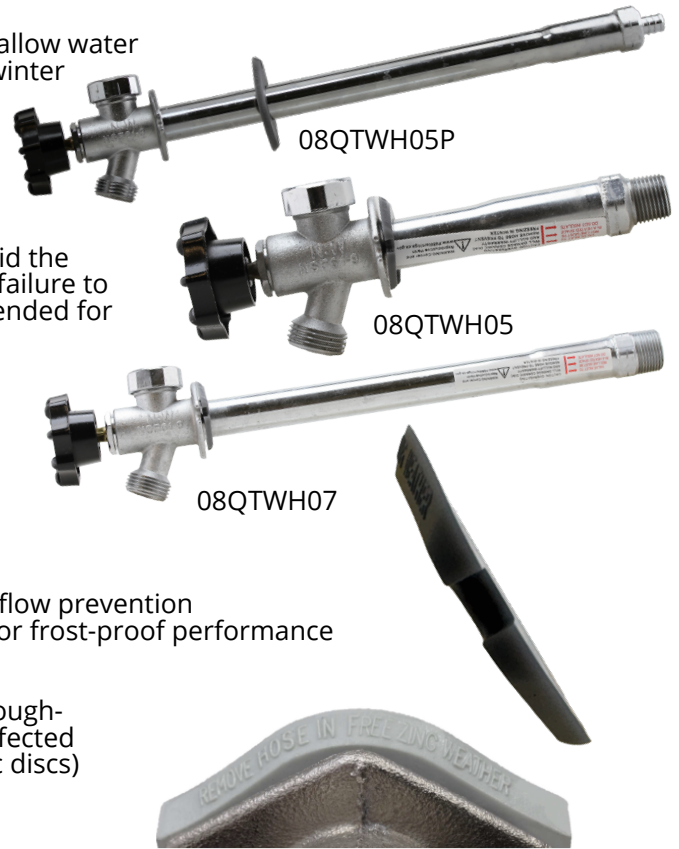

Grey flange wedge can be used to ensure upward tilt.
"REMOVE HOSE IN FREEZING WEATHER"

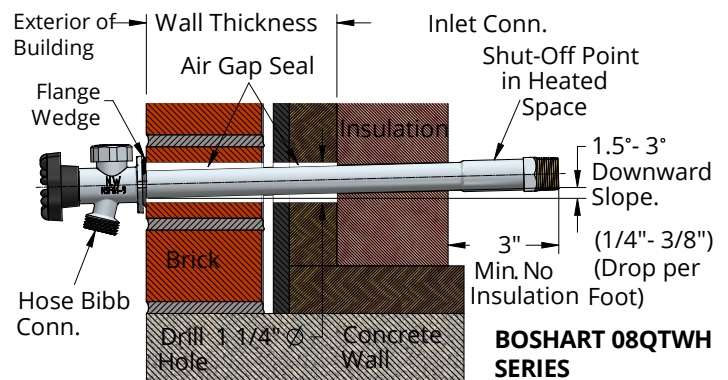

25 Whaley Avenue, PO Box 310, Milverton, ON CANADA N0K 1M0
Tel: 800-561-3164
VISIT US ONLINE AT BOSHART.COM



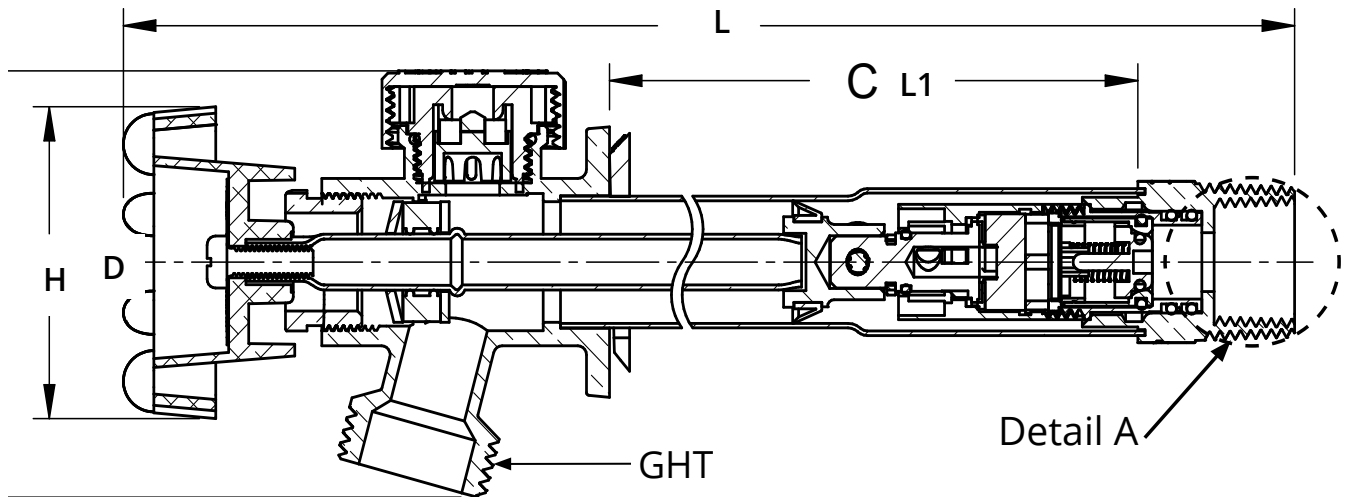

****Short burst of water can occur from vacuum breaker but will stop. If it continues to leak, vacuum breaker should be replaced****

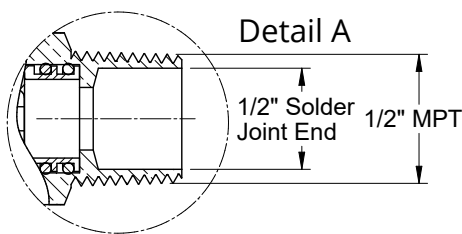

08QTWH05 Series End
■ IC 1

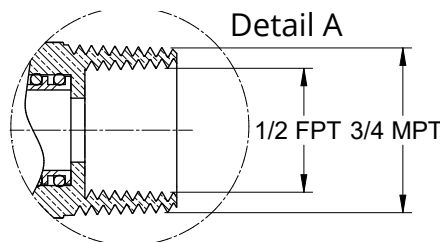

08QTWH07 Series End
■ IC 2

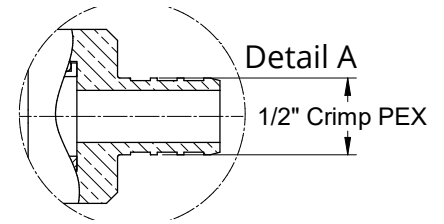

08QTWH05P Series End
■ IC 3

DIMENSIONS												
Part No.	Inlet Connection	Size	D		L		L1		H		Weight	
			in	mm	in	mm	in	mm	in	mm	lbs	grams
08QTWH05-040NL	1/2" MPT x C (Solder/Sweat)	4"	2.20	56.00	8.78	222.80	4.00	101.60	3.20	81.30	1.15	520
08QTWH05-060NL		6"			10.78	273.60	6.00	152.40			1.23	560
08QTWH05-080NL		8"			12.78	324.40	8.00	203.20			1.29	585
08QTWH05-100NL		10"			14.78	375.20	10.00	254.00			1.36	615
08QTWH05-120NL		12"			16.78	426.00	12.00	304.80			1.43	650
08QTWH05-140NL		14"			18.79	476.80	14.00	355.60			1.50	680
08QTWH07-100NL	3/4" MPT x 1/2" FPT	10"	2.20	56.00	14.78	375.20	10.00	254.00	3.20	81.30	1.40	635
08QTWH07-120NL		12"			16.78	426.00	12.00	304.80			1.48	670
08QTWH07-140NL		14"			18.79	476.80	14.00	355.60			1.54	700
08QTWH05P-080NL	1/2" PEX	8"	2.20	56.00	12.78	324.40	8.00	203.20	3.20	81.30	1.29	585
08QTWH05P-100NL		10"			14.78	375.20	10.00	254.00			1.36	615
08QTWH05P-120NL		12"			16.78	426.00	12.00	304.80			1.43	650
08QTWH05P-140NL		14"			18.79	476.80	14.00	355.60			1.50	680



25 Whaley Avenue, PO Box 310, Milverton, ON CANADA N0K 1M0
Tel: 800-561-3164
VISIT US ONLINE AT BOSHART.COM



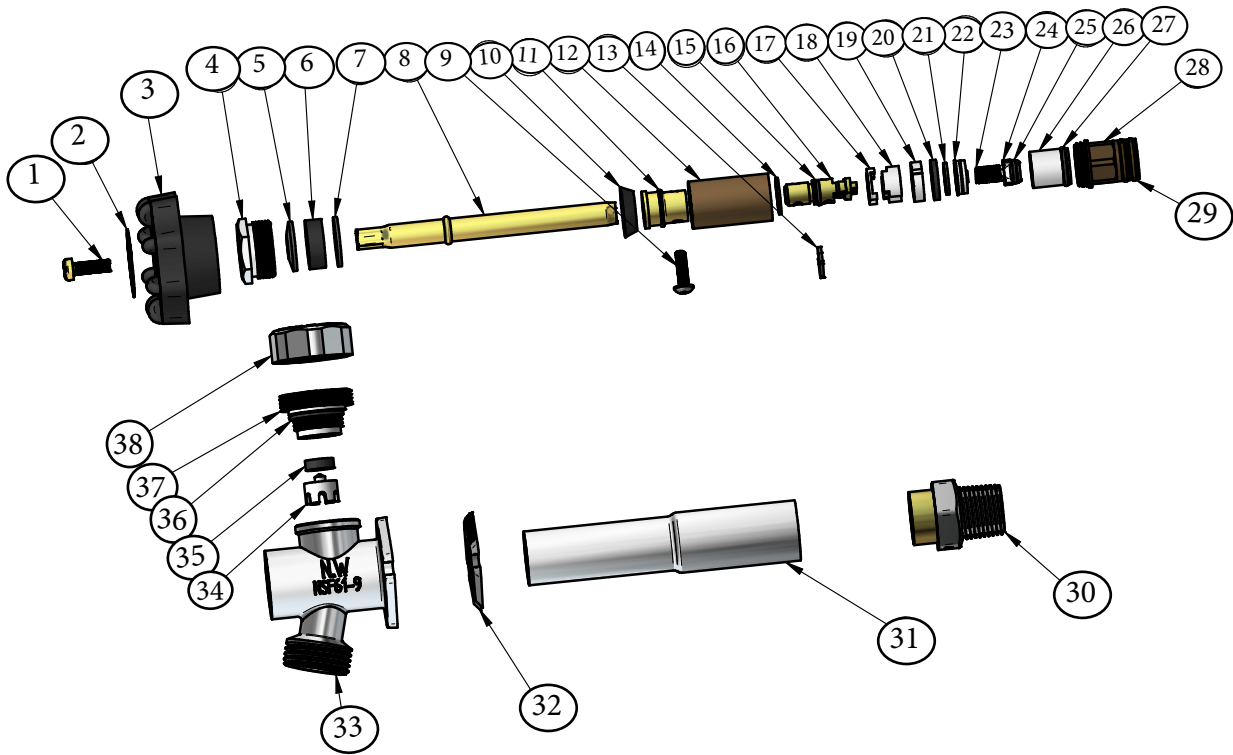

Material List		
Part No.	Part Name	Material
1	Handle Screw	C26000 NL Brass
2	Name Plate	Aluminum
3	Handwheel	Aluminum
4	Stem Packing Nut	C3604 Brass
5	Stem Packing Washer	SS304 Stainless Steel
6	Stem Packing	NBR (Nitrile Butadiene Rubber)
7	Stem Packing Flat Washer	SS304 Stainless Steel
8	Stem Pipe	C27000 NL Brass
9	Set Screw	SS304 Stainless Steel
10	Cup Washer	NBR (Nitrile Butadiene Rubber)
11	Stem Connector	C46400 NL Brass
12	Cartridge Body	C46400 NL Brass
13	C Clip	SS304 Stainless Steel
14	Plastic Square Ring	PTFE (Polytetrafluoroethylene)
15	Cartridge Stem O-Ring	NBR (Nitrile Butadiene Rubber)
16	Cartridge Stem	C46400 NL Brass
17	Ceramic Fixer	POM (Polyoxymethylene)
18	Ceramic Disc	Ceramic
19	Ceramic Disc	Ceramic

20	Cartridge Square Ring	EPDM (Ethylene Propylene Diene Monomer)
21	Brass Square Ring	C46400 NL Brass
22	Check Valve Seat	POM (Polyoxymethylene)
23	Check Valve Spring	SS304 Stainless Steel
24	Check Valve Piston	POM (Polyoxymethylene)
25	Check Valve Piston O-Ring	NBR (Nitrile Butadiene Rubber)
26	Check Valve Retainer	POM (Polyoxymethylene)
27	Check Valve O-Ring	NBR (Nitrile Butadiene Rubber)
28	Cartridge End	C46400 NL Brass
29	Cartridge End O-Ring	Viton
30	Adapter	C46400 NL Brass
31	Tube	C27000 NL brass
32	Flange Wedge/Insert Spacer	POM (Polyoxymethylene)
33	Valve Body	C6802 NL Bronze
34	Vacuum Breaker Disk	POM (Polyoxymethylene)
35	Vacuum Breaker Seat	NBR (Nitrile Butadiene Rubber)
36	Vacuum Breaker Body O-Ring	NBR-RUBBER
37	Vacuum Breaker Body	POM
38	Vacuum Breaker Cap	ABS Plastic



25 Whaley Avenue, PO Box 310, Milverton, ON CANADA N0K 1M0
 Tel: 800-561-3164
 VISIT US ONLINE AT BOSHART.COM



REPLACEMENT PARTS

REPLACEMENT PARTS		
Part No.	Description	Components
08QTDHPT-HDK	Replacement Handle Kit	1, 2, 3
08QTDHPT-SPK	Replacement Stem Packing Kit	4, 5, 6, 7
08QTDHPT-SA04	4" Replacement Stem Assembly	8 to 29
08QTDHPT-SA06	6" Replacement Stem Assembly	
08QTDHPT-SA08	8" Replacement Stem Assembly	
08QTDHPT-SA10	10" Replacement Stem Assembly	
08QTDHPT-SA12	12" Replacement Stem Assembly	
08QTDHPT-SA14	14" Replacement Stem Assembly	
08QTDHPT-ORK	Replacement O-Ring Kit	29 (Qty. 2)
08QTDHPT-INS	Replacement Insert Spacer	32
08QTDHPT-VBK	Replacement Vacuum Breaker Kit	34, 35, 36, 37
08QTDHPT-VBC	Replacement Vacuum Breaker Cap	38

08QTDHPT-HDK - Replacement Handle

- Kit includes handwheel, nameplate and screw

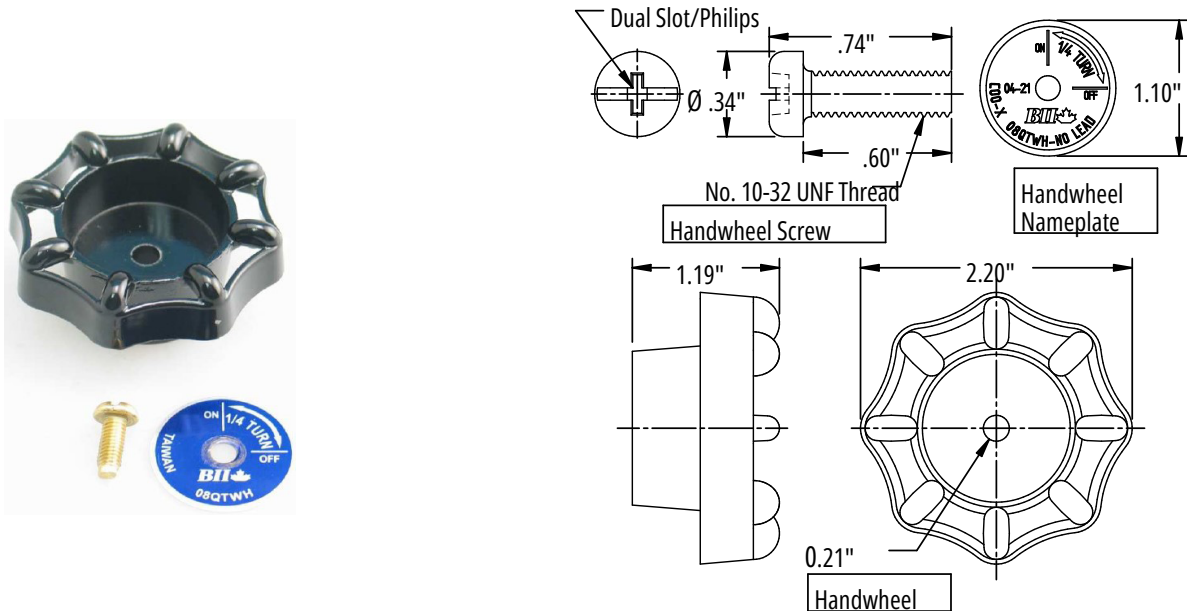

25 Whaley Avenue, PO Box 310, Milverton, ON CANADA N0K 1M0
 Tel: 800-561-3164
 VISIT US ONLINE AT BOSHART.COM



08QTHWPT-SPK - Stem Packing Kit

- Includes bonnet, washer, stem packing and stop washer

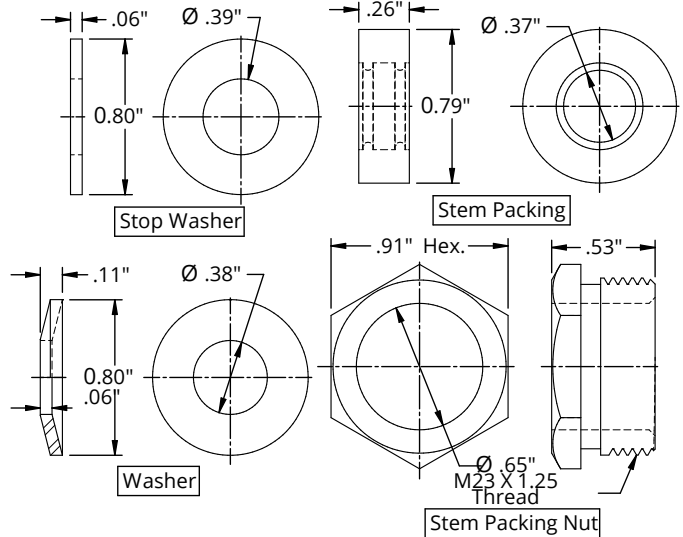

Determining Stem Length

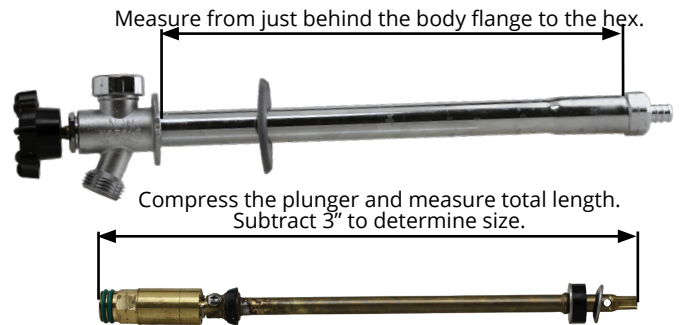

08QTHWPT-SA(xx) - Stem Assembly

- Available in 4", 6", 8", 10", 12" and 14" lengths

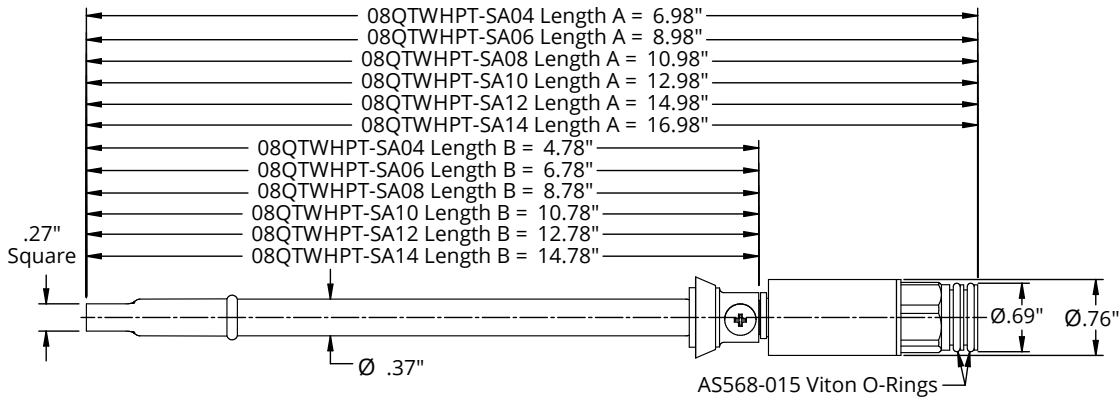

08QTHWPT-ORK - O-Ring Kit

- Kit includes 2 O-rings
- AS568-113 Standard O-Ring Size

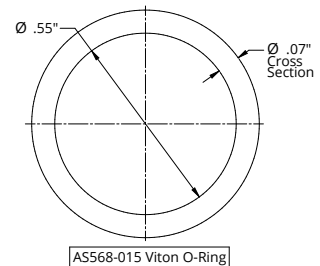

BOSHART
INDUSTRIES

25 Whaley Avenue, PO Box 310, Milverton, ON CANADA N0K 1M0
Tel: 800-561-3164
VISIT US ONLINE AT BOSHART.COM

For more information on installation, adjustment, repair & operation, visit Boshart Knowledge Base at SUPPORT.BOSHART.COM



08QTHWPT-INS - Insert Spacer

- Ensures downward tilt

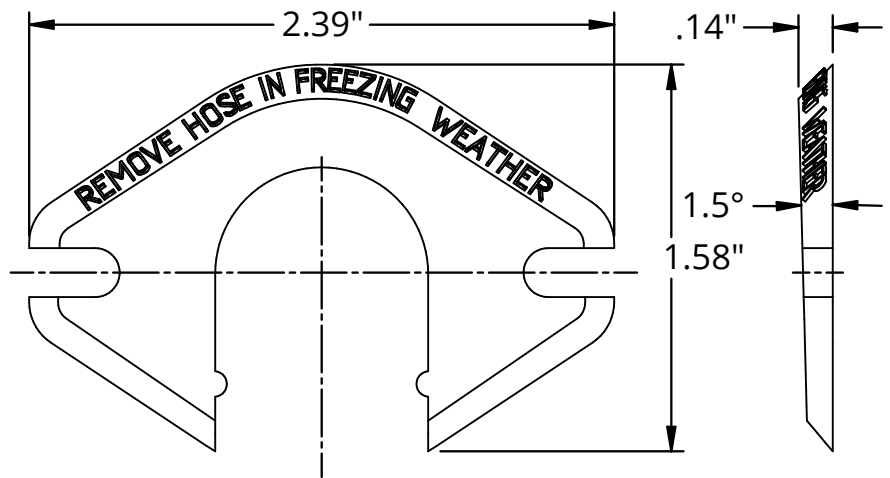

08QTHWPT-VBK - Vacuum Breaker Kit

- Gaskets included

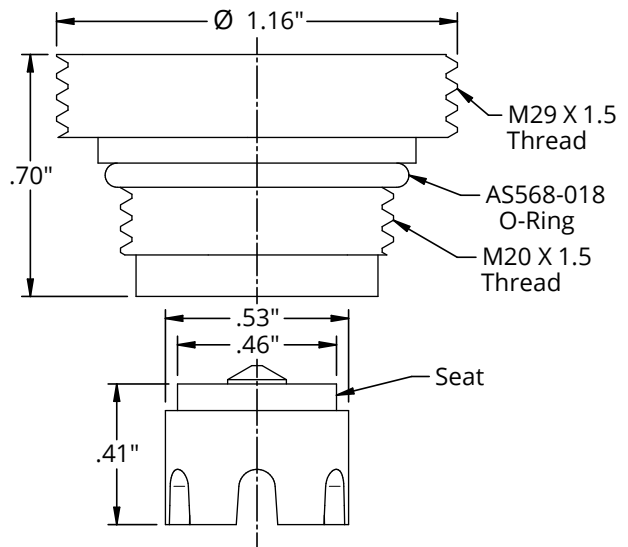
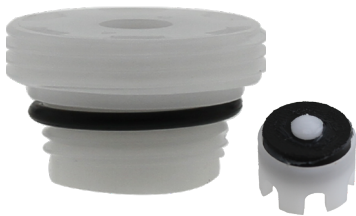

08QTHWPT-VBC - Vacuum Breaker Cap

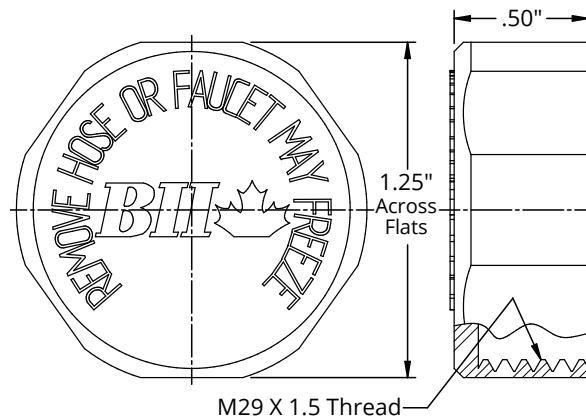

BOSHART
INDUSTRIES

25 Whaley Avenue, PO Box 310, Milverton, ON CANADA N0K 1M0
Tel: 800-561-3164
VISIT US ONLINE AT BOSHART.COM

For more information on installation, adjustment, repair & operation, visit Boshart Knowledge Base at SUPPORT.BOSHART.COM



0865(P) SERIES - NON-FREEZE WALL HYDRANT WITH SELF DRAINING VACUUM BREAKER

Non-Freeze Wall Hydrant can be installed through a wall and allow water to drain back out of the valve so freezing will not occur in the winter season. This prevents the need for winterizing and allows outdoor access to water year round.

CAUTION: Boshart will not be liable for any damage caused by failure to remove the hose or any attached device. Failure to do so may cause the hydrant to freeze. Freezing can lead to the tube bursting, resulting in property damage and may void the warranty. Boshart will not be liable for any damage caused by failure to remove the hose or attached device. Wall hydrants are not intended for potable water supply.

FEATURES:

- Integral anti-siphon vacuum breaker to allow air to enter the valve, ensuring the valve drains completely
- Stem comes with a weep hole to allow back pressure relief when water is trying to siphon back into the homes water supply
- Chrome plated brass body, tube and adapter
- Black cast handwheel
- Inlet cartridge has built in spring loaded check valve for backflow prevention
- Grey flange wedge to support proper drainage angle, which is crucial for frost-proof performance

SPECIFICATION:

- Inlet connections:
 - Dual threaded/solder. Thread conform to ANSI/ASME B1.20.1 Pipe Threads, General Purpose (Inch). Sweat connection conforms to ANSI B16.18 Cast Copper Alloy Solder Joint Pressure Fittings
 - Crimp PEX conforms to ASTM F1807 Standard Specification for Metal Insert Fittings Utilizing a Copper Crimp Ring for SDR9 Cross-linked Polyethylene (PEX) Tubing and SDR9 Polyethylene of Raised Temperature (PE-RT) Tubing
- Outlet Connection:
 - Hose thread 3/4" GHT conforms to ASME B1.20.7 Standard for Garden Hose Coupling Screw Threads (inch)

RATINGS:

- Max Temperature Rating: 160°F (71°C)
- Max Pressure Rating: 125 PSI

CERTIFICATION:

- CSA Standard B125.1 Plumbing Fittings Certified
- ASSE Standard 1019 Performance Requirements for Vacuum Breaker Wall Hydrants, Freeze Resistant, Automatic Draining Type Certified
- ASME Standard A112.18.1 Certified Plumbing Supply Fittings



Grey flange wedge can be used to ensure downward tilt.
"REMOVE HOSE IN FREEZING WEATHER"

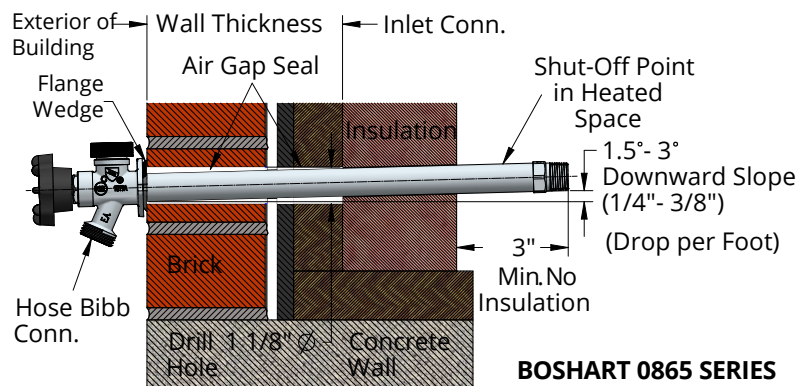

BOSHART 0865 SERIES

BOSHART
INDUSTRIES

25 Whaley Avenue, PO Box 310, Milverton, ON CANADA N0K 1M0
Tel: 800-561-3164
VISIT US ONLINE AT BOSHART.COM

For more information on installation, adjustment, repair & operation, visit Boshart Knowledge Base at SUPPORT.BOSHART.COM



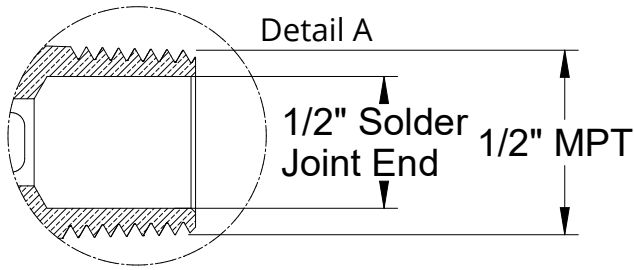

0865 End

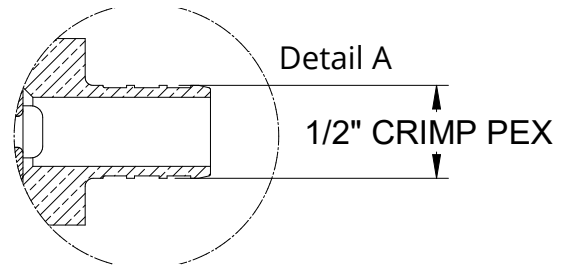

0865P End

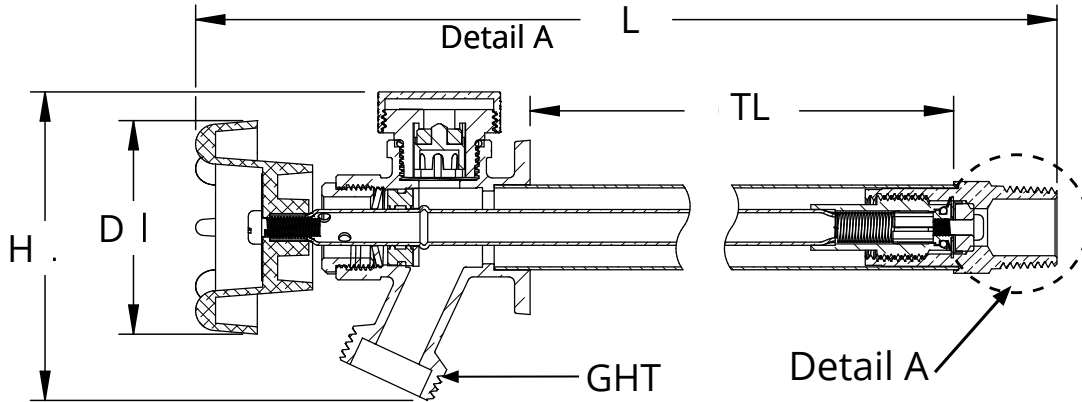

Short bursts of water can occur from vacuum breaker, but will stop. If it continues to leak, vacuum breaker should be replaced

DIMENSIONS												
Part No.	Inlet Connection (IC)	Size	D		L		TL		H		Weight	
			inches	mm	inches	mm	inches	mm	inches	mm	lbs	grams
0865-040	1/2" MPT or Copper	4"	2.20	56.00	8.64	219.50	3.96	100.70	3.07	78.00	0.98	443.5
0865-060	1/2" MPT or Copper	6"			10.65	270.50	5.97	151.70			1.04	469.7
0865-080	1/2" MPT or Copper	8"			12.66	321.50	7.98	202.70			1.11	502.9
0865-100	1/2" MPT or Copper	10"			14.67	372.50	9.99	253.70			1.18	534.1
0865-120	1/2" MPT or Copper	12"			16.67	423.50	12.00	304.70			1.24	563.8
0865-140	1/2" MPT or Copper	14"			18.68	474.50	14.00	355.70			1.31	595.3
0865-160	1/2" MPT or Copper	16"			20.69	525.50	16.01	406.70			1.38	623.2
0865-180	1/2" MPT or Copper	18"			22.70	576.50	18.02	457.70			1.42	645.00
0865-200	1/2" MPT or Copper	20"			24.70	627.50	20.03	508.70			1.52	688.2
0865-220	1/2" MPT or Copper	22"			26.71	678.50	22.04	559.70			1.58	714.8
0865-240	1/2" MPT or Copper	24"			28.72	729.50	24.04	610.70			1.61	728.4
PEX Connection												
0865P-040	1/2" PEX	4"	2.20	56.00	8.64	219.50	3.96	100.70	3.07	78.00	0.96	434.5
0865P-060	1/2" PEX	6"			10.65	270.50	5.97	151.70			1.02	464.4
0865P-080	1/2" PEX	8"			12.66	321.50	7.98	202.70			1.08	490.9
0865P-100	1/2" PEX	10"			14.67	372.50	9.99	253.70			1.16	526.7
0865P-120	1/2" PEX	12"			16.67	423.50	12.00	304.70			1.23	558.6
0865P-140	1/2" PEX	14"			18.68	474.50	14.00	355.70			1.29	585.3



25 Whaley Avenue, PO Box 310, Milverton, ON CANADA N0K 1M0
 Tel: 800-561-3164
 VISIT US ONLINE AT BOSHART.COM



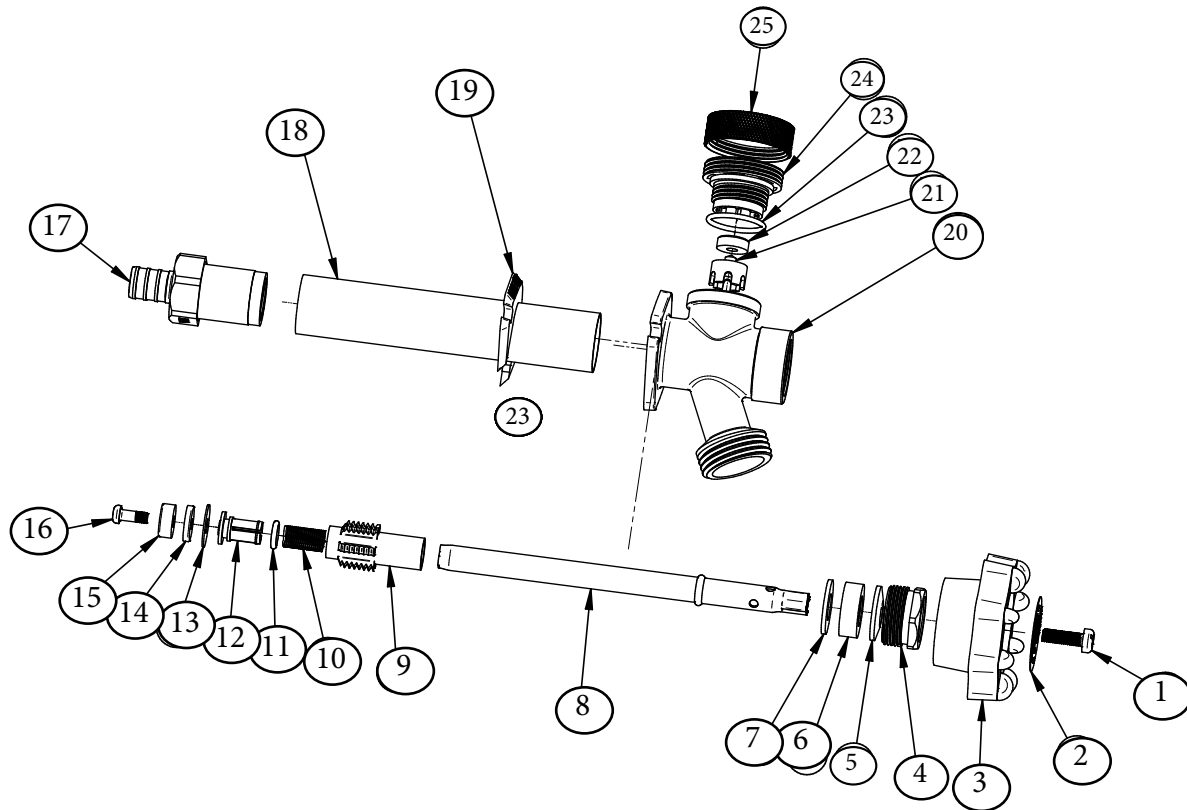

MATERIAL LIST

Part No.	Part Name	Material
1	Handle Screw	C26000 NL Brass
2	Name Plate	Aluminium
3	HandWheel	Black Powder Coated Aluminium
4	Stem Packing Nut	Chrome Plated C37700 Brass
5	Stem Packing Washer	304 Stainless Steel
6	Stem Packing	NBR (Nitrile Butadiene Rubber)
7	Stem Packing Flat Washer	SS304 Stainless Steel
8	Stem Pipe	C27000 NL Brass
9	Stem	C37700 Brass
10	Spring	SS304 Stainless Steel
11	Spring Seat O-Ring	NBR (Nitrile Butadiene Rubber)
12	Spring Seat	C37700 Brass
13	Flapper	NBR (Nitrile Butadiene Rubber)

14	Seat Holder	C26000 NL Brass
15	Seat Packing	NBR (Nitrile Butadiene Rubber)
16	Seat Screw	C26000 NL Brass
17	Adapter	Chrome Plated C37700 Brass
18	Tube	Chrome Plated C27000 NL Brass
19	Flange Wedge / Insert Spacer	POM (Polyoxymethylene)
20	Valve Body	Chrome Plated C85700 Brass
21	Vacuum Breaker Disk	POM (Polyoxymethylene)
22	Vacuum Breaker Seat	NBR (Nitrile Butadiene Rubber)
23	Vacuum Breaker Body O-Ring	NBR (Nitrile Butadiene Rubber)
24	Vacuum Breaker Body	POM (Polyoxymethylene)
25	Vacuum Breaker Cap	Chrome Plated C37700 Brass



25 Whaley Avenue, PO Box 310, Milverton, ON CANADA N0K 1M0
 Tel: 800-561-3164
VISIT US ONLINE AT BOSHART.COM

For more information on installation, adjustment, repair & operation, visit Boshart Knowledge Base at SUPPORT.BOSHART.COM

REPLACEMENT PARTS

REPLACEMENT PARTS		
Part No.	Description	Components
0865PT-99	Replacement Packing Screw	4
0865PT-03	Replacement Handle	1
0865PT-SA04	4" Replacement Stem Assembly	4-16
0865PT-SA06	6" Replacement Stem Assembly	
0865PT-SA08	8" Replacement Stem Assembly	
0865PT-SA10	10" Replacement Stem Assembly	
0865PT-SA12	12" Replacement Stem Assembly	
0865PT-SA14	14" Replacement Stem Assembly	
0865PT-PA	Replacement Plunger Assembly	10 to 16
0865PT-123	Vacuum Breaker Body	21 to 24
0865PT-98	Replacement Seat Packing	15
0865PT-10	Vacuum Breaker Cap	25

0865PT-99 - Replacement Packing Screw

- UNC #8-32

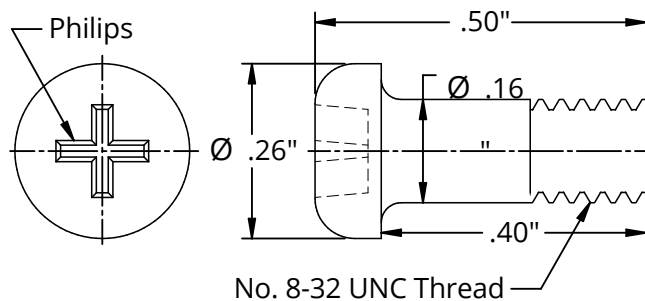

0865PT-03 - Replacement Handle

- Name plate and screw not included

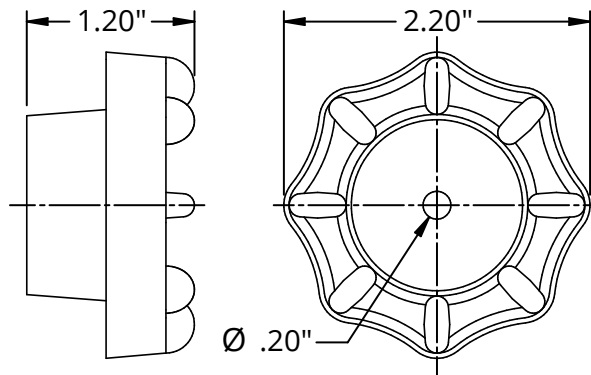

25 Whaley Avenue, PO Box 310, Milverton, ON CANADA N0K 1M0
 Tel: 800-561-3164
 VISIT US ONLINE AT BOSHART.COM



Determining Stem Length

0865PT-SA(xx) - Stem Assembly

- Contains items 4-16
- Available in 4", 6", 8", 10", 12" and 14" lengths

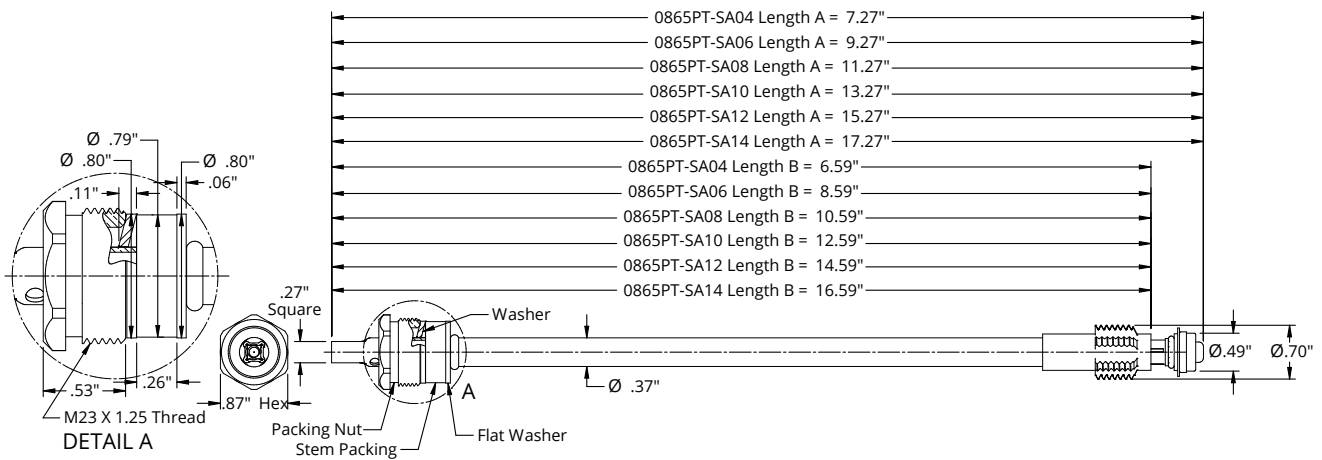
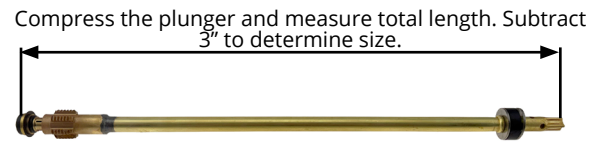
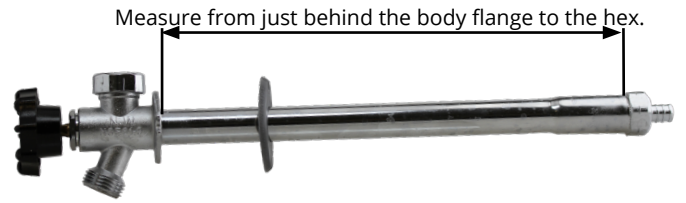

0865PT-PA - Replacement Plunger Assembly

- Includes spring

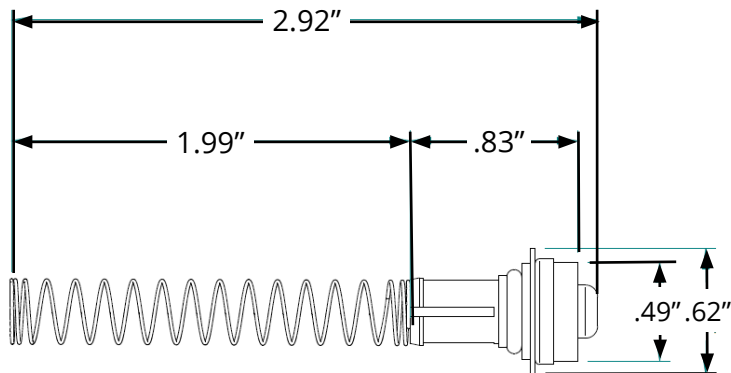

BOSHART
INDUSTRIES

25 Whaley Avenue, PO Box 310, Milverton, ON CANADA N0K 1M0
Tel: 800-561-3164
VISIT US ONLINE AT BOSHART.COM

For more information on installation, adjustment, repair & operation, visit Boshart Knowledge Base at SUPPORT.BOSHART.COM



0865PT-123 - Vacuum Breaker Body

- Gaskets included

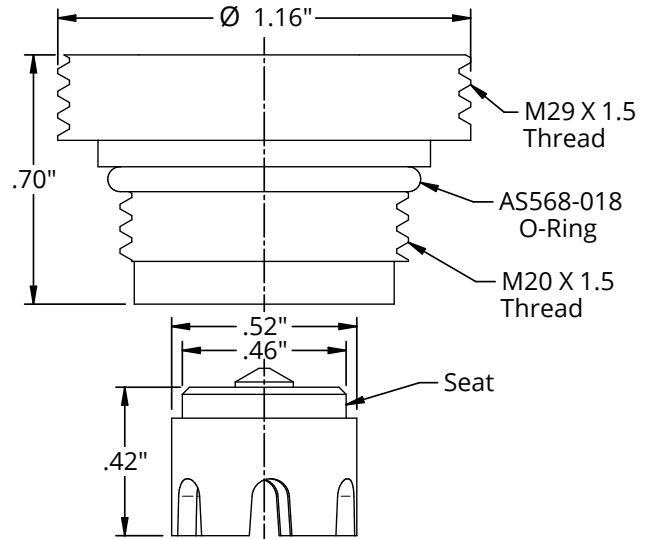
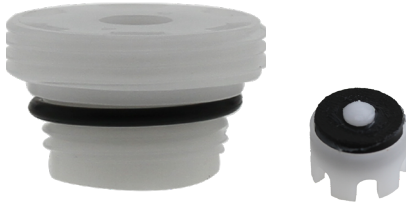

0865PT-98 - Replacement Seat Packing

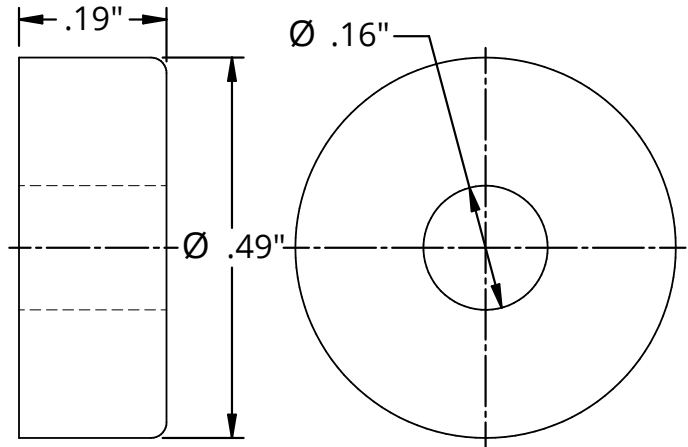

0865PT-10 - Vacuum Breaker Cap

- Cap is threaded inside

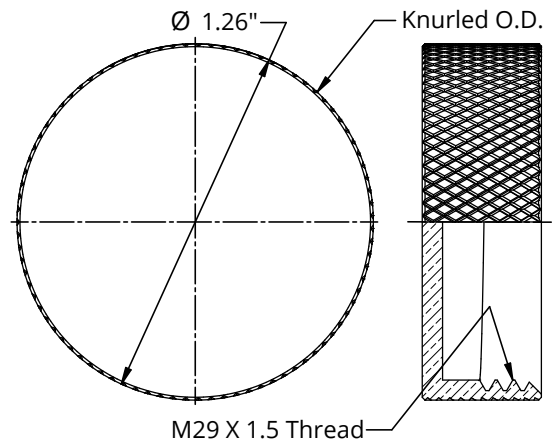

25 Whaley Avenue, PO Box 310, Milverton, ON CANADA N0K 1M0
 Tel: 800-561-3164
VISIT US ONLINE AT BOSHART.COM

For more information on installation, adjustment, repair & operation, visit Boshart Knowledge Base at SUPPORT.BOSHART.COM



0865(P)-NL SERIES - NON-FREEZE WALL HYDRANT WITH SELF DRAINING VACUUM BREAKER

Boshart's Non-Freeze Wall Hydrants can be installed through a wall and allow water to drain back out of the valve so freezing will not occur in the winter season. This prevents the need for winterizing and allows outdoor access to water year round.

FEATURES:

- Integral anti-siphon vacuum breaker to allow air to enter the valve, ensuring the valve drains completely
- Stem comes with a weep hole to allow back pressure relief when water is trying to siphon back into the homes water supply
- Chrome plated no lead brass body, tube and adapter
- Black cast handwheel
- Inlet cartridge has built in spring loaded check valve for back flow prevention
- Sloped flange to support proper drainage, this is necessary for frost-proof performance
- Grey gap spacer wedge to ensure downward tilt

SPECIFICATION:

- Inlet Connection:
 - Threads conform to ANSI/ASME B1.20.1 Pipe Threads, General Purpose (Inch)
 - Sweat connection conforms to ANSI B16.18 Cast Copper Alloy Solder Joint Pressure Fittings
 - Crimp PEX end conform to ASTM F1807 Standard Specification for Metal Insert Fittings Utilizing a Copper Crimp Ring for SDR9 Cross-linked Polyethylene (PEX) Tubing and SDR9 Polyethylene of Raised Temperature (PE-RT) Tubing
- Outlet Connection:
 - ASME B1.20.7 Standard for Garden Hose Coupling Screw Threads (inch)

RATINGS:

- Max Pressure Rating: 125 PSI
- Max Temperature Rating: 140°F (60°C)

CERTIFICATION:

- NSF/ANSI Standard 61 Certified (Drinking Water System Components - Health Effects)
- NSF/ANSI Standard 372 Certified (Drinking Water System Components - Lead Content)
- CSA Standard B125.1 Plumbing Fittings Certified
- ASSE Standard 1019 Performance Requirements for Vacuum Breaker Wall Hydrants, Freeze Resistant, Automatic Draining Type Certified
- ASME A112.18.1 Certified Plumbing Supply Fittings



Grey gap spacer wedge can be used to ensure downward tilt.
"REMOVE HOSE IN FREEZING WEATHER"

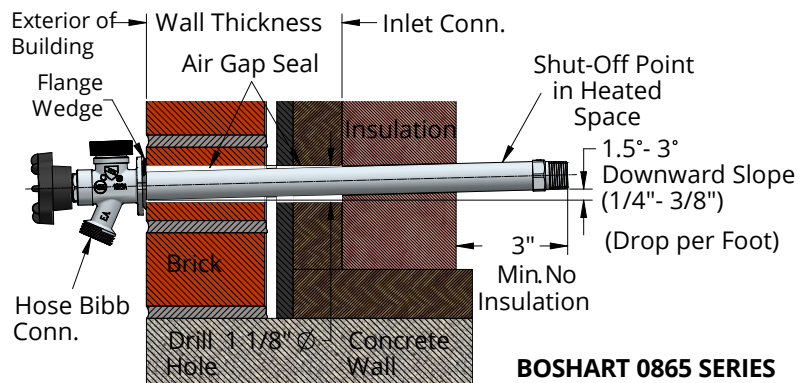

BOSHART 0865 SERIES

BOSHART
INDUSTRIES

25 Whaley Avenue, PO Box 310, Milverton, ON CANADA N0K 1M0
Tel: 800-561-3164
VISIT US ONLINE AT BOSHART.COM



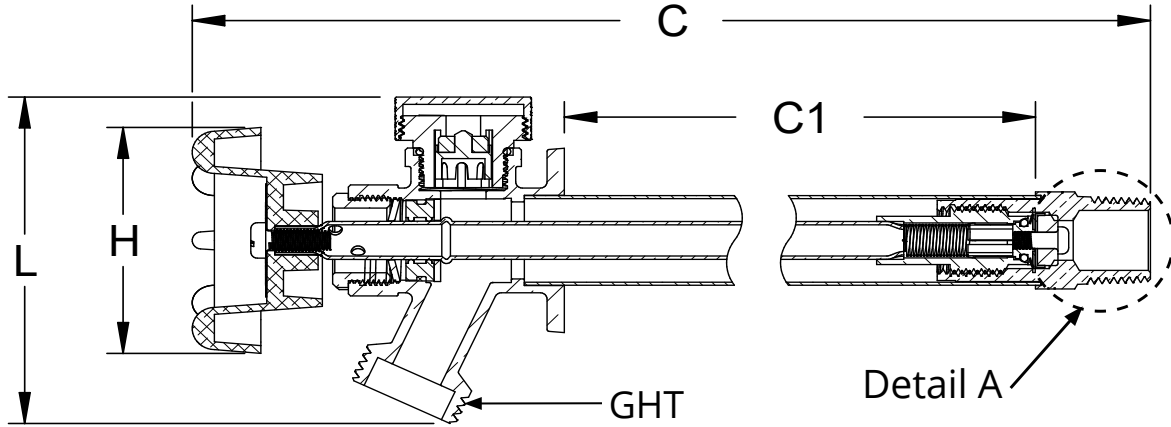
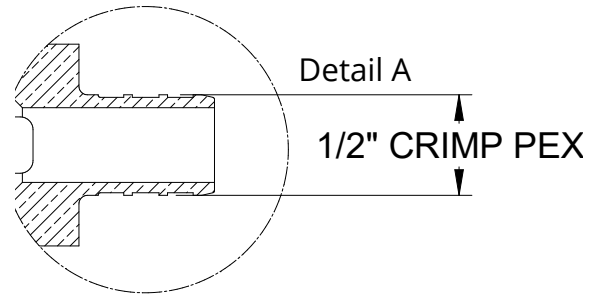
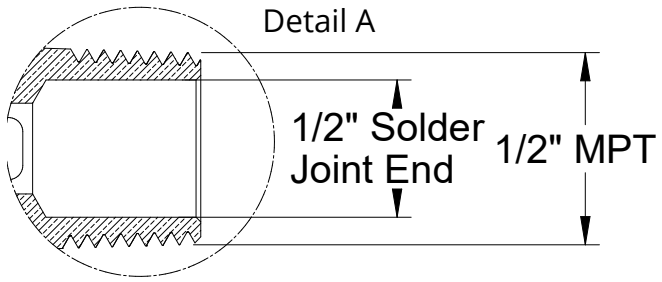

Short bursts of water can occur from vacuum breaker, but will stop. If it continues to leak, vacuum breaker should be replaced

DIMENSIONS												
Part No.	Inlet Connection	Size	H		C		C1		L		Weight	
			inches	mm	inches	mm	inches	mm	inches	mm	lbs	grams
0865-040NL	1/2" MPT or Copper	4"	2.20	56.00	8.64	219.50	3.96	100.70	3.07	78.00	1.10	500.00
0865-060NL	1/2" MPT or Copper	6"	2.20	56.00	10.65	270.50	5.97	151.70	3.07	78.00	1.19	540.00
0865-080NL	1/2" MPT or Copper	8"	2.20	56.00	12.66	321.50	7.98	202.70	3.07	78.00	1.26	570.00
0865-100NL	1/2" MPT or Copper	10"	2.20	56.00	14.67	372.50	9.99	253.70	3.07	78.00	1.32	600.00
0865-120NL	1/2" MPT or Copper	12"	2.20	56.00	16.71	424.50	12.00	304.70	3.07	78.00	1.43	650.00
0865-140NL	1/2" MPT or Copper	14"	2.20	56.00	18.72	475.50	14.00	355.70	3.07	78.00	1.52	690.00
PEX Connection												
0865P-040NL	1/2" PEX	4"	2.20	56.00	8.62	219.00	3.96	100.70	3.07	78.00	1.12	510.00
0865P-060NL	1/2" PEX	6"	2.20	56.00	10.63	270.00	5.97	151.70	3.07	78.00	1.15	520.00
0865P-080NL	1/2" PEX	8"	2.20	56.00	12.64	321.00	7.98	202.70	3.07	78.00	1.30	590.00
0865P-100NL	1/2" PEX	10"	2.20	56.00	14.65	372.00	9.99	253.70	3.07	78.00	1.41	640.00
0865P-120NL	1/2" PEX	12"	2.20	56.00	16.69	442.00	12.00	304.70	3.07	78.00	1.52	690.00
0865P-140NL	1/2" PEX	14"	2.20	56.00	18.70	475.00	14.00	355.70	3.07	78.00	1.57	710.00



25 Whaley Avenue, PO Box 310, Milverton, ON CANADA N0K 1M0
Tel: 800-561-3164
VISIT US ONLINE AT BOSHART.COM



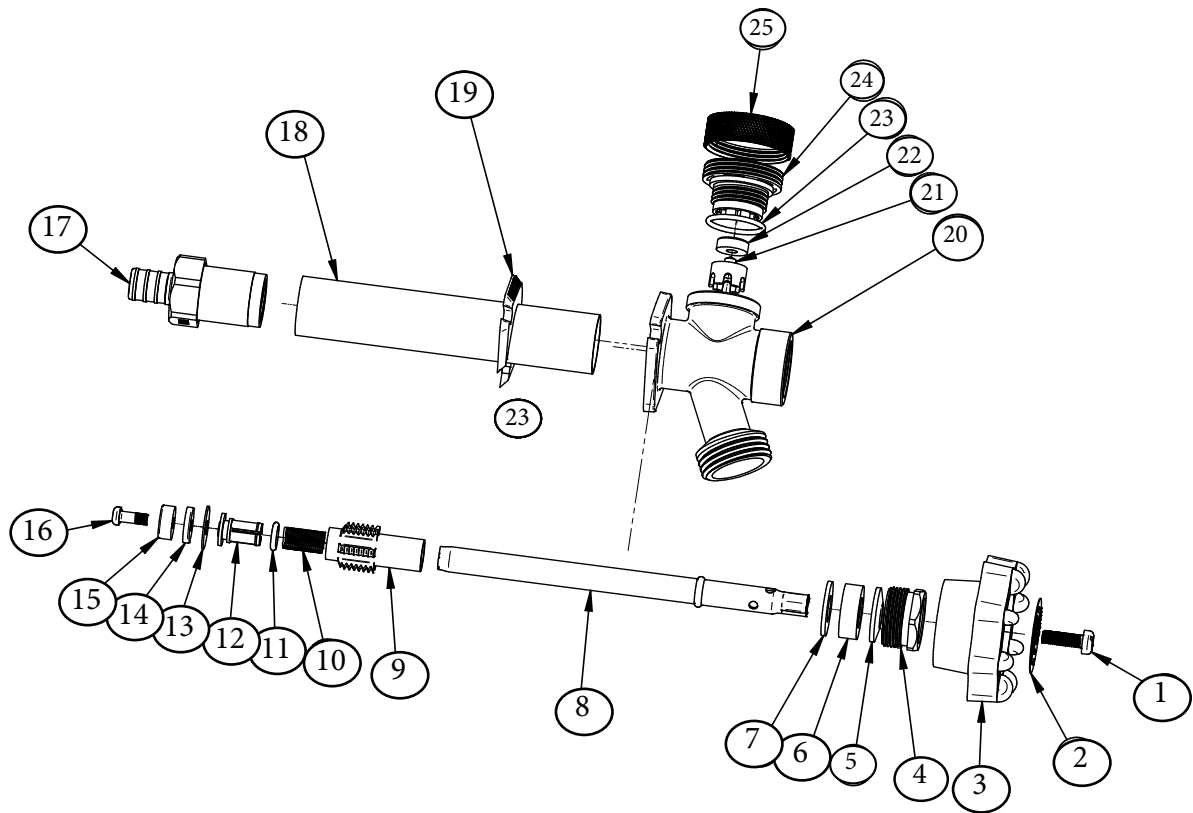

MATERIAL LIST		
Part No.	Part Name	Material
1	Handle Screw	C26000 No Lead Brass
2	Name Plate	Aluminium
3	HandWheel	Black Powder Coated Aluminium
4	Stem Packing Nut	Chrome Plated C37700 Brass
5	Stem Packing Washer	SS304 Stainless Steel
6	Stem Packing	NBR (Nitrile Butadiene Rubber)
7	Stem Packing Flat Washer	SS304 Stainless Steel
8	Stem Pipe	C27000 No Lead Brass
9	Stem	C46400 No Lead Brass
10	Spring	SS304 Stainless Steel
11	Spring Seat O-Ring	NBR (Nitrile Butadiene Rubber)
12	Spring Seat	C46400 No Lead Brass

13	Flapper	NBR (Nitrile Butadiene Rubber)
14	Seat Holder	C26000 No Lead Brass
15	Seat Packing	NBR (Nitrile Butadiene Rubber)
16	Seat Screw	C26000 No Lead Brass
17	Nipple	Chrome Plated C46400 No Lead Brass
18	Tube	Chrome Plated C27000 No Lead Brass
19	Flange Wedge / Insert Spacer	POM (Polyoxymethylene)
20	Valve Body	Chrome Plated C46400 No Lead Brass
21	Vacuum Breaker Disk	POM (Polyoxymethylene)
22	Vacuum Breaker Seat	NBR (Nitrile Butadiene Rubber)
23	Vacuum Breaker Body O-Ring	NBR (Nitrile Butadiene Rubber)
24	Vacuum Breaker Body	POM (Polyoxymethylene)
25	Vacuum Breaker Cap	C37700 Brass

BOSHART
INDUSTRIES

25 Whaley Avenue, PO Box 310, Milverton, ON CANADA N0K 1M0
Tel: 800-561-3164
VISIT US ONLINE AT BOSHART.COM

For more information on installation, adjustment, repair & operation, visit Boshart Knowledge Base at SUPPORT.BOSHART.COM



REPLACEMENT PARTS

REPLACEMENT PARTS		
Part No.	Description	Components
0865PT-99	Replacement Packing Screw	4
0865PT-03	Replacement Handle	1
0865PT-SA04	4" Replacement Stem Assembly	4-16
0865PT-SA06	6" Replacement Stem Assembly	
0865PT-SA08	8" Replacement Stem Assembly	
0865PT-SA10	10" Replacement Stem Assembly	
0865PT-SA12	12" Replacement Stem Assembly	
0865PT-SA14	14" Replacement Stem Assembly	
0865PT-PA	Replacement Plunger Assembly	10 to 16
0865PT-123	Vacuum Breaker Body	21 to 24
0865PT-98	Replacement Seat Packing	15
0865PT-10	Vacuum Breaker Cap	25

0865PT-99 - Replacement Packing Screw

- UNC #8-32

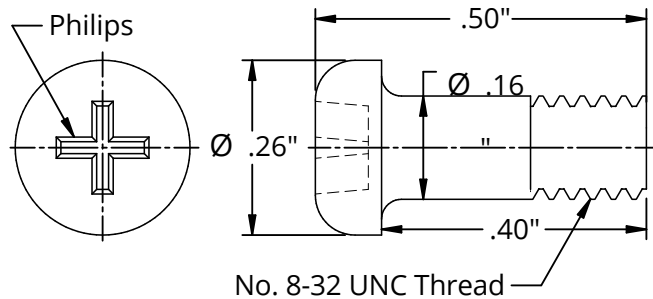

0865PT-03 - Replacement Handle

- Name plate and screw not included

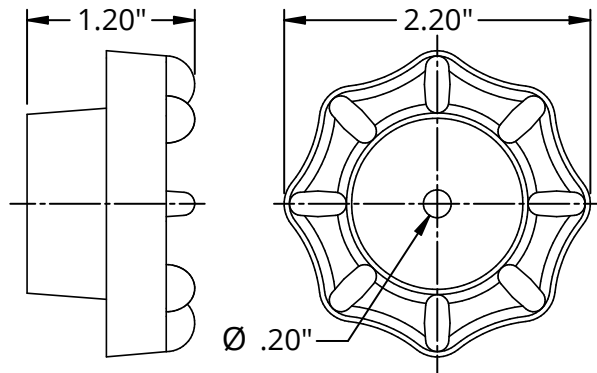

25 Whaley Avenue, PO Box 310, Milverton, ON CANADA N0K 1M0
 Tel: 800-561-3164
VISIT US ONLINE AT BOSHART.COM



Determining Stem Length

0865PT-SA(xx) - Stem Assembly

- Contains items 4-16
- Available in 4", 6", 8", 10", 12" and 14" lengths



Measure from just behind the body flange to the hex.

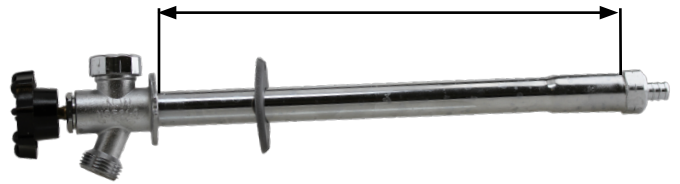

Compress the plunger and measure total length. Subtract 3" to determine size.

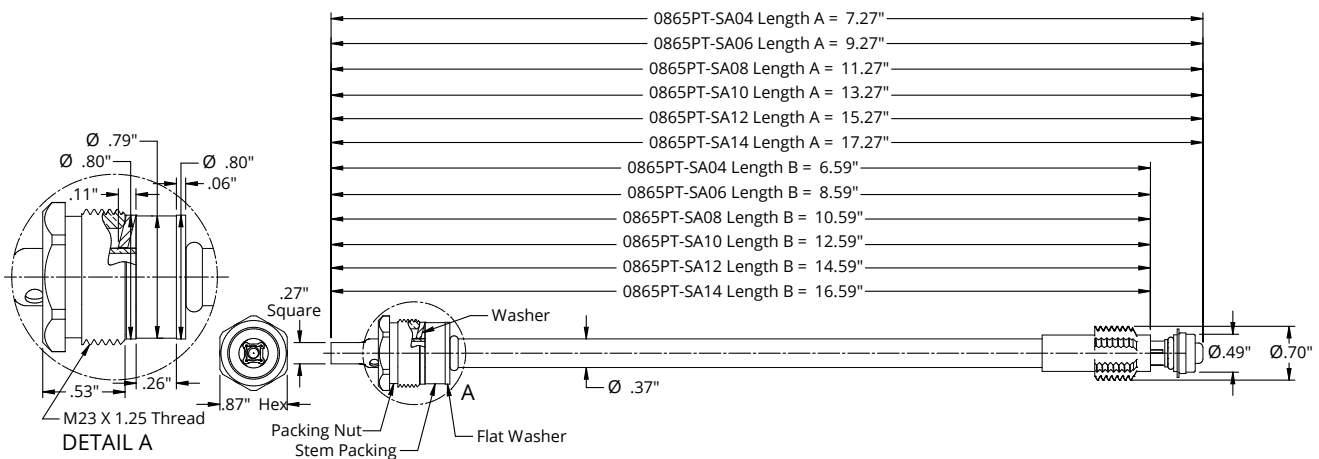
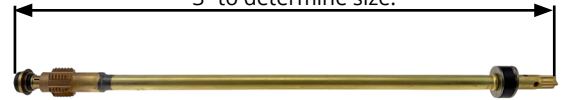

0865PT-PA - Replacement Plunger Assembly

- Includes spring

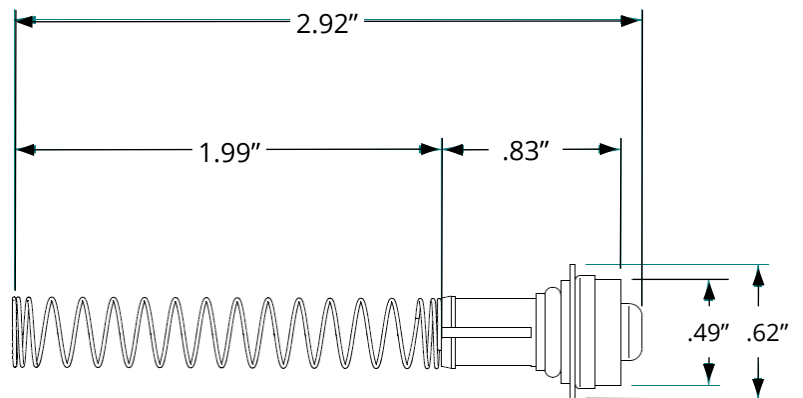

BOSHART
INDUSTRIES

25 Whaley Avenue, PO Box 310, Milverton, ON CANADA N0K 1M0
Tel: 800-561-3164
VISIT US ONLINE AT BOSHART.COM

For more information on installation, adjustment, repair & operation, visit Boshart Knowledge Base at SUPPORT.BOSHART.COM



0865PT-123 - Vacuum Breaker Body

- Gaskets included

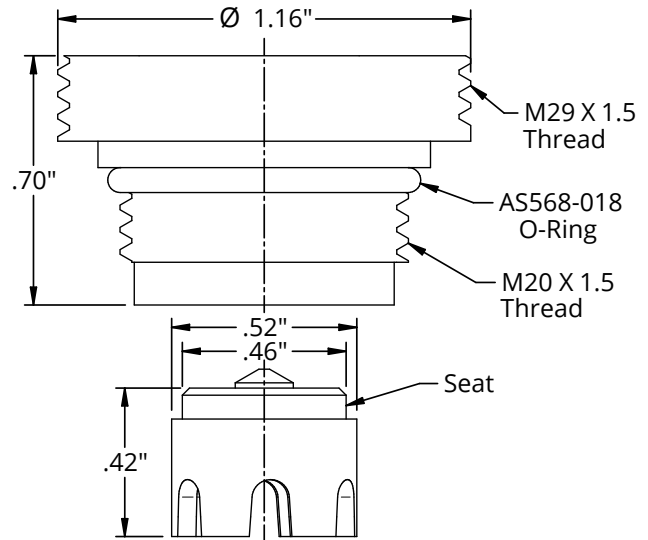
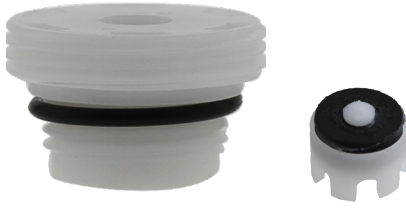

0865PT-98 - Replacement Seat Packing

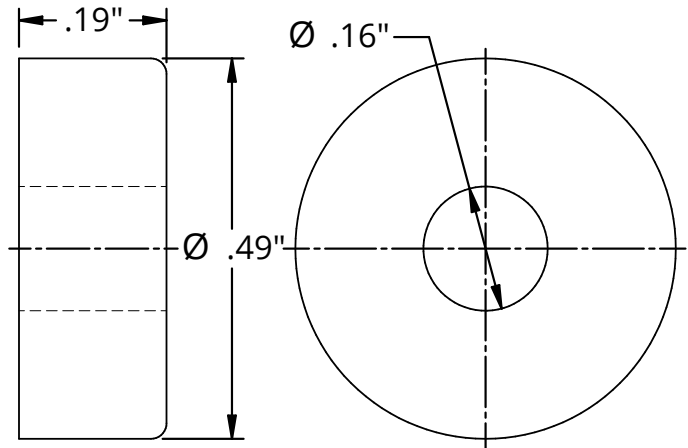

0865PT-10 - Vacuum Breaker Cap

- Cap is threaded inside

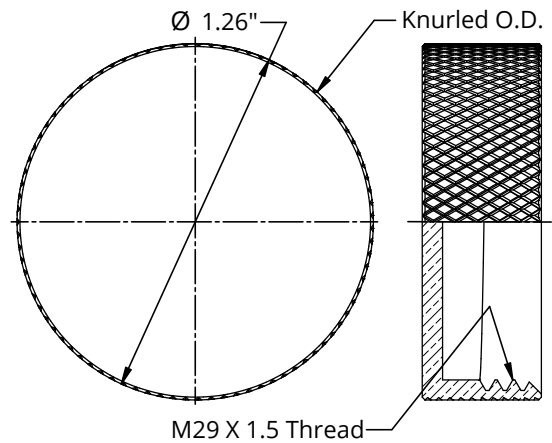

BOSHART
INDUSTRIES

25 Whaley Avenue, PO Box 310, Milverton, ON CANADA N0K 1M0
Tel: 800-561-3164
VISIT US ONLINE AT BOSHART.COM

For more information on installation, adjustment, repair & operation, visit Boshart Knowledge Base at SUPPORT.BOSHART.COM



How do you install an 0861/0865 frost-free wall hydrant?

Before getting started, it is extremely important to make sure you have an appropriate length of wall hydrant for your wall thickness. The inlet connection MUST extend through the wall and any insulation so that the connection is inside the warm space at a position that is easily accessible to make the water line connection.

Step # 1- Drill a 1-1/8" diameter hole on a 5° upward angle from the outside to ensure you have sufficient downward slope to the outlet for drainage. Drill through the foundation wall or the floor joist band. Then insert the faucet tube from the outside. **WARNING:** Do not drill the hole horizontally. A 1-1/8" diameter hole will only allow the tube to be installed at approximately up to 1.5°. It does not have enough play to properly slope the wall hydrant.

Step #2 - Position the faucet so that the faucet's spout is pointing directly downward. To check the spout's position from the inside of the building, place the "TOP" marking on the hex by the inlet connection pointing up.

Step #3- Place the angled, wedge-shaped, plastic flange with the thick side upwards to ensure the hydrant tube has a minimum of a 5° angle downwards to the spout to insure proper drainage. Then, secure the wall faucet flange on to the wall with two #8 or #10 wood or masonry screws depending on your construction. Failure to ensure the 5° angle will result in trapped water which will cause the wall faucet to freeze and fail, damaging internal components or in the worst-case scenario, burst the tube and potentially cause water damage.

Step #4 - If you are using the internal solder (sweat) connection, the stem assembly MUST be removed to prevent damage to the rubber seals due to excessive heat. To remove the stem assembly, unscrew the hexagon nut behind the hand wheel and then pull the valve stem straight out of the tube by pulling on the handwheel.

Step #5 - Fill the free space (air gap) around the tube with caulking to seal the air gap.

Step #6 - When insulating, DO NOT insulate beyond 3" from the inlet connection. The 3" section of the tube from the inlet end must not be insulated from the warmth of the building to ensure it does not freeze. Insulating too close to or over the inlet connection may cause the wall faucet to freeze and fail, damaging internal components, or in worst-case scenario, burst the tube and potentially cause water damage.

IMPORTANT WARNINGS:

#1 - Winterization: When the cold weather arrives, it is crucial to remove the hose to ensure proper drainage. Failure to remove the hose WILL cause the wall faucet to freeze and fail, damaging internal components. It is not a product defect! Turn the handle to the closed position (clockwise) and always detach the hose from the spout if there is any chance of frost. Damage due to freezing will void warranty.

#2 - Keep Inlet Heated: Wall hydrants are frost-proof because the water is shut off inside the heated portion of the building. If the building is left unheated for an extended period, the water supply lines must be drained and all plumbing fixtures and components properly winterized to prevent freezing.

For troubleshooting and selection guide, visit our Knowledge Base.

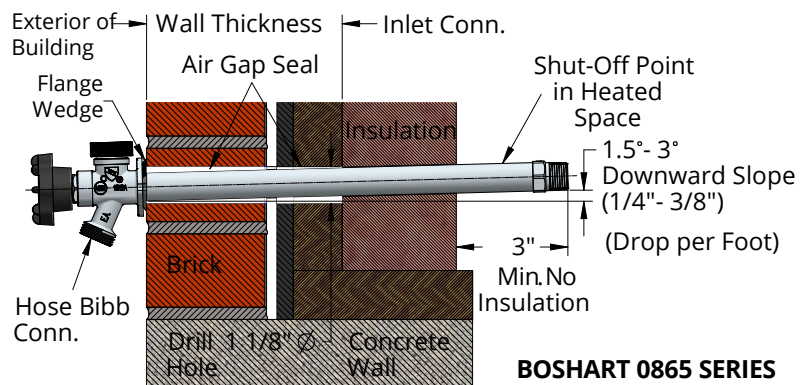

BOSHART
INDUSTRIES

25 Whaley Avenue, PO Box 310, Milverton, ON CANADA N0K 1M0
Tel: 800-561-3164
VISIT US ONLINE AT BOSHART.COM

For more information on installation, adjustment, repair & operation, visit Boshart Knowledge Base at SUPPORT.BOSHART.COM

How do you install a 08QTWH quarter turn frost-free wall hydrant?

Before getting started, it is extremely important to make sure you have an appropriate length of wall hydrant for your wall thickness. The inlet connection MUST extend through the wall and any insulation so that the connection is inside the warm space at a position that is easily accessible to make the water line connection.

Step # 1- Drill a 1-1/4" diameter hole on a 5° upward angle from the outside to ensure you have sufficient downward slope to the outlet for drainage. Drill through the foundation wall or the floor joist band. Then insert the faucet tube from the outside. **WARNING:** Do not drill the hole horizontally. A 1-1/4" diameter hole will only allow the tube to be installed at approximately up to 1.5°. It does not have enough play to properly slope the wall hydrant.

Step #2 - Position the faucet so that the faucet's spout is pointing directly downward. To check the spout's position from the inside of the building, place the "TOP" marking on the hex by the inlet connection pointing up.

Step #3- Place the angled, wedge-shaped, plastic flange with the thick side upwards to ensure the hydrant tube has a minimum of a 5° angle downwards to the spout to insure proper drainage. Then, secure the wall faucet flange on to the wall with two #8 or #10 wood or masonry screws depending on your construction. Failure to ensure the 5° angle will result in trapped water which will cause the wall faucet to freeze and fail, damaging internal components or in the worst-case scenario, burst the tube and potentially cause water damage.

Step #4 - If you are using the internal solder (sweat) connection, the stem assembly MUST be removed to prevent damage to the rubber seals due to excessive heat. To remove the stem assembly, unscrew the hexagon nut behind the hand wheel and then pull the valve stem straight out of the tube by pulling on the handwheel.

Step #5 - Fill the free space (air gap) around the tube with caulking to seal the air gap.

Step #6 - When insulating DO NOT insulate beyond 3" from the inlet connection. The 3" section of the tube from the inlet end must not be insulated from the warmth of the building to ensure it does not freeze. Insulating too close to or over the inlet connection may cause the wall faucet to freeze and fail, damaging internal components, or in worst-case scenario, burst the tube and potentially cause water damage.

IMPORTANT WARNINGS:

#1 - Winterization: When the cold weather arrives, it is crucial to remove the hose to ensure proper drainage. Failure to remove the hose WILL cause the wall faucet to freeze and fail, damaging internal components. It is not a product defect! Turn the handle to the closed position (clockwise) and always detach the hose from the spout if there is any chance of frost.

#2 - Keep Inside Heated: Wall hydrants are frost-proof because the water is shut off inside the heated portion of the building. If the building is left unheated for an extended period, the water supply lines must be drained and all plumbing fixtures and components properly winterized to prevent freezing.

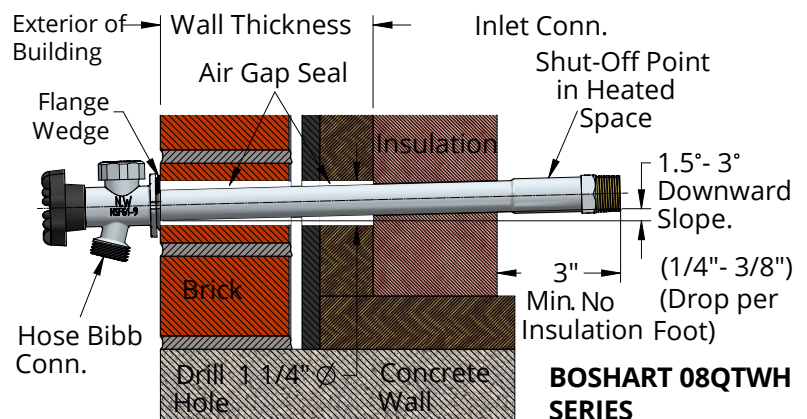

For troubleshooting and selection guide, visit our Knowledge Base.



BOSHART
INDUSTRIES

25 Whaley Avenue, PO Box 310, Milverton, ON CANADA N0K 1M0
Tel: 800-561-3164
VISIT US ONLINE AT BOSHART.COM

For more information on installation, adjustment, repair & operation, visit Boshart Knowledge Base at SUPPORT.BOSHART.COM

